

CITY ROADMAP FOR E-MOBILITY: UPTAKE OF EV IN URBAN AREAS OF URUGUAY



PROJECT PARTNERS



ABOUT

To provide an input for Departmental Governments in planning the transition to low-carbon urban mobility by developing electric vehicles as a scalable solution to reduce emissions in public transport and urban logistics

TITLE

City Roadmap for E-Mobility: Uptake of EV In Urban Areas of Uruguay

CONTRIBUTERS

Wuppertal Institute, The Urban Electric Mobility Initiative (UEMI), Municipality of Montevideo (IM) - Transport Division, Municipality of Montevideo (IM), Mobility Planning Unit, Ministry of Environment (MA) - National Directorate for Climate Change, National Energy Directorate (DNE-MIEM) - Demand, Access and Energy Efficiency Area

REVIEWERS

María Rosa Muñoz (Wuppertal Institute)
 Juan Pedro Carriquiry (UEMI)
 Carolina Romero (IM)

DISCLAIMER

The views expressed in this publication are the sole responsibility of the authors named and do not necessarily reflect the views of the European Commission.

LAYOUT

Yasin Imran Rony, WI

PICTURES

All the pictures are provided by the SOL+ partners

June, 2024





Executive Summary

In recent decades, the transport sector has been identified as one of the major contributors to GHG emissions worldwide and the possibility of electrifying transport has gained prominence as a possible solution to this problem. In terms of GHG emissions, in 2020 Uruguay emitted 5,878 kt of CO₂, representing 0.02% of total global CO₂ emissions. The contribution of transport to the CO₂ emissions has increased significantly over the last decades, from 40% in 2000 to 60% in 2020 (EDGAR, 2022).

Uruguay has undergone a transformation of its electricity grid, moving from an electricity system heavily dependent on fossil fuels to one based on renewable energies and 91% of the electricity generation currently comes from renewable sources such as wind power, solar, hydro and biomass (Preliminary BEN, 2022). Taking into account also that 100% of the country's population has access to electricity (World Bank, 2020), Uruguay is an ideal scenario for the development of e-mobility because electric vehicles (EVs) can be charged with emission-free energy in their generation.

In relation to this, Uruguay has set 2025 targets on e-mobility in its first NDC to the Paris Agreement, such as the implementation of an energy efficiency labeling system for vehicles, the introduction of EVs in public and private transport, and the installation and development of a fast charging network. Looking further into the long term, the Ministry of Environment stated that by 2035 all new passenger vehicles will be zero emission, by 2045 all new freight vehicles will be zero emission and by 2050 all motorbikes will be electric (ECLP, 2021).

To achieve these objectives, Uruguay promotes the transition to e-mobility with different incentives such as tax reductions when importing an EV (exemption from IMESI and TGA), subsidies for incorporating e-taxis and e-buses in public transport fleets, patent discount, reimbursement of a percentage of the cost of purchasing an LEV, etc. In addition, through the MOVÉS project, programmes were carried out in which companies could test EVs and evaluate their performance in the company's activities before purchasing them.

In terms of charging infrastructure, Uruguay has an EV charging network of 150 chargers managed and installed by the national electric company UTE. In 2017, the UTE Electric Route was inaugurated, connecting the main coastal cities with charging points every 60 km. A fast charging network is currently starting to be developed, for which UTE will be installing 23 DC fast chargers by the summer of 2023.

In this context, SOLUTIONSplus has a project in Montevideo consisting of two components. The first component seeks to build a multimodal charging hub at the Ciudadela Terminal capable of charging e-buses, taxis and light electric vehicles (LEVs). The second component aims to provide financial, technical and business model assistance for the promotion of local LEVs manufacturing.

This roadmap is a strategic document that aims to provide an input for Departmental Governments (DGs) in planning the transition to e-mobility. The document seeks to demonstrate the development of EVs as



a scalable solution in Montevideo and its Metropolitan Area in the field of public transport and urban logistics in order to support the country to start the transition towards a low-carbon urban mobility and to comply with the Paris Agreement. It should be noted that the roadmap does not aim to define a national e-mobility strategy for Uruguay, as this process requires in-depth and coordinated work among multiple government agencies and stakeholders, but rather to provide basic inputs to facilitate the process of developing and planning a public e-mobility policy.

In particular, the document refers to the two demonstration cases of the SOLUTIONSplus project. With regard to the Ciudadela Terminal component, the demonstration project is intended to be a pilot project that will generate the first experience in the construction of a charging hub of this type and this roadmap aims to be an input for the DGs to replicate this project in other terminals. On the LEVs manufacturing component, this roadmap suggests a series of actions to be considered in order to establish a profitable LEVs manufacturing scheme in Uruguay.

In July 2022, a workshop was held between the main stakeholders involved in the transition to e-mobility in Uruguay, such as national ministries, the Municipality of Montevideo and UTE. The results of the workshop identify some current barriers to the adoption of EVs and an action plan to address them, which was used as input for the elaboration of a timeline of measures to be implemented to scale up the project components in this roadmap. From the results of the workshop and other stakeholder exchanges, the need to move forward on some key issues for e-mobility such as training and education, charging ecosystem, regulatory measures, urban planning and battery handling was identified. The roadmap therefore elaborates on these areas of interest in five sections at the end of the document by identifying the needs that exist for the development of e-mobility and how to address them.



Table of Contents

Executive Summary	1
List of figures and tables	4
List of Abbreviations	7
Acknowledgements	11
1. Vision	12
2. Objectives	13
3. Background – Where are we now?	14
3.1. Urban mobility context in Montevideo	15
3.2. Current Policy Framework and Market Readiness for the deployment of e-mobility	18
3.2.1. Policy on climate change	21
3.2.2. Existing regulations	23
3.2.3. Policy and regulation gaps	24
3.2.4. Business environment	25
3.2.5. Capacity building	26
3.2.6. Key Stakeholders	28
3.3. Demo project	32
3.3.1. Component 1: Charging infrastructure for Ciudadela Terminal.	32
3.3.2. Component 2: Local manufacturing of e-cargo bikes and e-cargo tricycles	36
4. Approach – Methodology	39
5. The Roadmap – Where are we going?	41
5.1. Vision	41
5.2. Specific objectives	42
5.3. Inputs	43
5.4. Timeline	48
5.4.1. Multimodal charging hub	48
5.4.2. Urban logistics	50
6. Implementation plan – How do we get there?	52
6.1. Focus area 1: Education and training	52
6.2. Focus area 2: Charging ecosystem	57
6.2.1. Charging infrastructure in Uruguay	57
6.2.2. New business models	60
6.3. Focus Area 3: Regulatory measures	62



6.3.1. Charging infrastructure	62
6.3.2. Financing plans and business models	63
6.3.3. Urban traffic and incentives	63
6.3.4. Noise pollution	64
6.3.5. Energy efficiency	65
6.3.6. Governmental units specialized in e-mobility	66
6.3.7. Battery handling	66
6.3.8. Promotion of local manufactured LEVs	67
6.3.9. EV homologation	67
6.3.10. Retrofitting and homologation	68
6.4. Focus Area 4: Urban planning	70
6.5. Focus Area 5: EV battery management	75
6.5.1. Battery repurposing or “second life”	75
6.5.2. Battery refurbishing	77
6.5.3. Battery recycling	80
7. Conclusions	82
8. References	85

List of figures and tables

Figure 1 - Share of electricity production from wind, 2021.

Figure 2 - Bicycle infrastructure in the historic center of Montevideo.

Figure 3 - Electric Route of UTE.

Figure 4 - Charging Network of Uruguay.

Table 1 - Targets of Uruguay's first NDC to reduce CO₂ emissions in the transport sector by 2025.

Table 2 - Trend and aspirational scenario projected in the Long-term Climate Strategy for the penetration of zero emission vehicles in the vehicle fleet.

Table 3 - Local start-ups working on e-mobility solutions.

Table 4 - Main obstacles that could slow down a transition to e-mobility in Montevideo.

Table 5 - Relevant stakeholders for Montevideo across the six stakeholder groups.

Figure 5 - Area view of the Ciudadela Terminal with the positioning of the different elements.

Figure 6 - South view with the proposal for a linear pedestrian and active mobility park.

Figure 7 - North view of the Terminal with the proposal for the location of different types of vehicles, chargers and infrastructure intervention.

Figure 8 - Map of the stakeholders involved in the activities of the construction of a multimodal charging hub in Ciudadela Terminal.

Figure 9 - Map of the stakeholders involved in the stage of the second component of the SOL+ demo project.

Figure 10 - Example of e-mobility solutions for manufacturing in Uruguay (GreenStar).

Figure 11 - Example of e-mobility solutions for manufacturing in Uruguay (Wheeel and CargoBike).

Table 6 - Main results of the workshop carried out among the SOLUTIONSplus project stakeholders.

Figure 12 - Current offer of e-mobility training in Uruguay.

Figure 13 - Future e-mobility education trajectory considered by UTU.

Figure 14 - Main sectors to be trained, areas of training, stakeholders and sources of training.

Figure 15 - Charging network of Uruguay with DC fast chargers.

Figure 16 - Charging network in the Metropolitan area of Montevideo.

Figure 17 - Main types of connectors used in Uruguay for EV charging and hourly evolution of the EVs charging tariff value.

Figure 18 - Existing and to be implemented regulatory measures for the promotion of e-mobility in Uruguay.

Figure 19 - Types of road infrastructure for bicycle circulation in Uruguay.

Figure 20 - Existing road infrastructure network for bicycle circulation in Montevideo.

Figure 21 - Existing bicycle parking lots in Montevideo.

Figure 22 - Life cycle of an EV battery from its manufacture to the possible management of the battery after reaching its EOL.



List of Abbreviations

- AC** - Alternating Current
- ACAU** - Automotive Trade Association of Uruguay
- ANCAP** - National Fuels Administration Alcohol and Portland
- ANDE** - National Development Agency
- ANII** - National Agency for Innovation and Research
- AUCI** - Uruguayan Agency for International Cooperation
- BEN** - National Energy Balance
- BESS** - Battery energy storage system
- BMS** - Battery Management System
- BOL** - Beginning of life
- BSE** - State Insurance Bank
- CAF** - Development Bank of Latin America
- CCAC** - Climate and Clean Air Coalition
- CCS** - Combined Charging System
- CCTCUM** - Consultative Council for Urban Transport
- CEFOMER** - Renewable Energy Operation and Maintenance Training Center
- CEUTA** - Uruguayan Center for Appropriate Technologies
- CI** - Congress of Mayors
- COETC** - Collective Transport Workers' and Employees' Cooperative
- COMAP** - Investment Law Enforcement Commission
- COME** - Micro East Bus Corporation
- COPSA** - Pando Bus Company S.A.
- CTT** - Tertiary Technical Course
- CUTCSA** - Uruguayan Public Transport Company S.A.
- DC** - Direct Current
- DG** - Departmental Government
- DNE** - National Energy Directorate
- DNI** - National Directorate of Industries
- ECLP** - Long-Term Climate Strategy
- EDGAR** - The Emissions Database for Global Atmospheric Research



EE - Energy Efficiency
EMC - Electromagnetic Compatibility
EOL - End of Life
ESCO - Energy Service Company
ESS - Energy Storage System
ETI - Energy Transition Index
EV - Electric Vehicle
FEIBIM - Iberoamerican Federation of Mechanical Engineering
FING - Engineering Faculty
FJR - Julio Ricaldoni Foundation
GDP - Gross Domestic Product
GEF - Global Environment Facility
GHG - Greenhouse Gas
GIMS - Inter-institutional Group on Sustainable Mobility
GTVE - Electric Vehicle Work Group
IAE - Institute of High Specialization
IEA - International Energy Agency
IDB - Inter-American Development Bank
IEC - International Electrotechnical Commission
IM - Municipality of Montevideo
IMESI - Specific Internal Tax
INE - National Statistical Institute
INEFOP - National Institute for Employment and Vocational Training
LEV - Light Electric Vehicle
LEZ - Low Emission Zone
MA - Ministry of Environment
MEC - Ministry of Education and Culture
MEF - Ministry of Economy and Finance
MEPS - Minimum Energy Performance Standards
MIEM - Ministry of Industry, Energy and Mining
MTOP - Ministry of Transport and Public Works
MVOT - Ministry of Housing & Planning



MVOTMA - Ministry of Housing, Planning & Environment
NDC - Nationally Determined Contribution
NUMP - National Urban Mobility Plan
OCP - Open Charge Point Protocol
OEM - Original Equipment Manufacturer
PFV - Green Fleet Plan
PTO - Public Transport Operator
SAVE - Supply Systems for Electric Vehicles
SME - Small and Medium-sized Enterprises
SNRCC - National System for Climate Change Response
SOL+ - SOLUTIONSplus
SOH - State of Health
STM - Metropolitan Transportation System
SUMP - Sustainable Urban Mobility Plans
TACU - Urban Cycling Self-Management Workshop
TGA - Global Tariff Rate
TNA - Training Needs Assessment
TUB - Technical University of Berlin
UCOT - Worker's Transport Cooperative Union
UDELAR - University of the Republic
UEMI - Urban Electric Mobility Initiative
UNIT - Uruguayan Institute of Technical Standards
UPM - Polytechnic University of Madrid
UTE - National Administration of Power Plants and Electric Transmissions
UTEC - Technological University of Uruguay
UTU - Labour University of Uruguay
WEF - World Economic Forum



Purpose	To provide an input for Departmental Governments in planning the transition to low-carbon urban mobility by developing electric vehicles as a scalable solution to reduce emissions in public transport and urban logistics.
Date	December 2022
Author	Federico Calvello
Coordination	María Rosa Muñoz (Wuppertal Institute) Juan Pedro Carriquiry (UEMI)
SOLUTIONSplus partners	<ul style="list-style-type: none"> - Wuppertal: German research center that aims to design transformation processes towards a climate friendly world by promoting sustainable use of resources. - The Urban Electric Mobility Initiative (UEMI): Platform launched by UN-Habitat to contribute to limiting global warming by reducing urban CO₂ emissions through the incorporation of e-mobility. - UN-Habitat: The United Nations Human Settlements Programme is mandated by the United Nations General Assembly to promote socially and environmentally sustainable towns and cities. It is responsible for the coordination of all matters related to urbanization and human settlements to build inclusive, safe, resilient and sustainable cities and communities. - Julio Ricaldoni Foundation: Non-profit organization created and linked to the Faculty of Engineering of the University of the Republic that has the support of the academic institution of the country, with a team of researchers and technicians with high recognition in different thematic areas of engineering, at regional and international level. - Municipality of Montevideo (IM): Local government of the capital of Uruguay, responsible among other things for the regulation of public transport, supervision of sanitation and cleanliness of the city.
Contributors	<ul style="list-style-type: none"> - Wuppertal Institute - The Urban Electric Mobility Initiative (UEMI) - Municipality of Montevideo (IM) - Transport Division - Municipality of Montevideo (IM) - Mobility Planning Unit - Ministry of Environment (MA) - National Directorate for Climate Change - National Energy Directorate (DNE-MIEM) - Demand, Access and Energy Efficiency Area
Reviewers	María Rosa Muñoz (Wuppertal Institute) Juan Pedro Carriquiry (UEMI) Carolina Romero (IM)



Acknowledgements

Thanks are due to the Municipality of Montevideo, the Ministry of Environment and the Ministry of Energy, Industry and Mining for their contributions to make the document as comprehensive and useful as possible for these bodies.

Also thanks to the reviewers from the Wuppertal Institute, UEMI and the Municipality of Montevideo for their comments, willingness and commitment to cooperate towards a zero emission transport in Uruguay. Finally, thanks the Julio Ricaldoni Foundation for implementing part of this project in the city of Montevideo.



1. Vision

The proposed vision in the present document is to create a sustainable, inclusive, and efficient urban transportation system in Montevideo city that prioritizes active mobility, promotes clean transportation options, and reduces noise pollution. It is envisioned as a city where walking, cycling, and public transportation are safe, convenient, and attractive options for all residents, and where electric vehicles and other low-emission modes of transport are seamlessly integrated into the transportation network. The proposed vision is to create a healthy, vibrant, and livable urban environment that supports the well-being and prosperity of all.

To achieve this vision, it is needed to prioritize policies, programs, and projects that:

- Promote walking and cycling as safe, convenient, and attractive modes of transport, by investing in infrastructure, education, and outreach programs, and by reducing car traffic in city centers and residential areas. This includes the development of a comprehensive network of bike lanes and pedestrian paths, as well as the provision of safe and secure bike parking facilities at key destinations.
- Improve public transportation, by investing in modern, low-emission buses and trams, improving the frequency, reliability, and accessibility of services, and integrating different modes of transport. This includes the development of new and improved transit hubs that offer seamless connections between different modes of transport, as well as the provision of real-time information and other traveler amenities.
- Reduce noise pollution from urban transportation, by promoting low-noise vehicles, investing in noise barriers and other mitigation measures, and raising awareness among residents and businesses. This includes the development of low-emission zones and other measures that limit the use of high-emission vehicles in densely populated areas.
- Support the uptake of low-emission modes of transport, including electric vehicles, by investing in charging infrastructure, offering incentives for purchasing and using these vehicles, and creating public awareness campaigns that highlight the benefits of clean transportation. This includes the development of a comprehensive network of electric vehicle charging stations that provide fast and convenient charging options for EV drivers.
- Improve urban planning and infrastructure, by prioritizing the needs of pedestrians, cyclists, and public transport users in all new development projects, and by promoting mixed-use development that supports compact and walkable neighborhoods. This includes the provision of safe and accessible pedestrian crossings, the development of public spaces that prioritize active mobility and social interaction, and the implementation of traffic calming measures that reduce the speed and volume of cars on residential streets.
- Reduce the number of personal cars on the road, by promoting car-sharing, ride-sharing, and other alternative transportation options, and by creating policies and programs that make car ownership less necessary and attractive. This includes the development of car-sharing programs



that offer affordable and convenient alternatives to car ownership, as well as the provision of incentives and subsidies for public transport users and active mobility commuters.

- Improve urban logistics, by promoting sustainable freight transport options, such as electric delivery vans and cargo bikes, and by creating policies and programs that encourage the consolidation and optimization of urban freight movements. This includes the development of logistics hubs and other facilities that facilitate the transfer of goods between different modes of transport, as well as the promotion of last-mile delivery options that reduce the need for large trucks and vans in densely populated areas.

This vision is aligned to the creation of healthier cities, sustainable, and equitable, and that serves as a model for other cities in the region and beyond.

2. Objectives

The objectives of this document aim to create a sustainable, inclusive, and efficient urban transportation system in Montevideo that prioritizes active mobility, promotes clean transportation options, and reduces noise pollution. These objectives are based on the principles of equity, social justice, and environmental sustainability, and they seek to improve the quality of life of all residents, while supporting the economic growth and competitiveness of the city. To achieve these objectives, the focus will be pointed to policies, programs, and projects that encourage walking, cycling, and public transportation, while reducing the dependence on personal cars, and promoting the use of low-emission modes of transport, such as electric vehicles. The improvement of urban infrastructure and logistics will be also prioritized, to ensure that the city is accessible, safe, and connected for all.

1. Create a safe, accessible and attractive environment for active mobility: the document aim to make walking, cycling, and other non-motorized modes of transport safe and attractive by investing in infrastructure, education, and outreach programs. The main goal is to increase the share of trips made by active modes of transport by prioritizing pedestrian and cycling infrastructure, improving connectivity, and creating a comprehensive network of bike lanes and pedestrian paths.
2. Improve public transportation: the paper strive to improve the reliability, frequency, and accessibility of public transport services. The aim is to provide residents with a high-quality public transport network that offers seamless connections between different modes of transport, is easy to use, and provides real-time information on schedules and services. This work points towards the adoption of low-emission buses, and the integration of different modes of transport to make public transportation an attractive option for all residents.
3. Reduce noise pollution from urban transportation: The roadmap aims to reduce noise pollution by promoting low-noise vehicles, investing in noise barriers and other mitigation measures, and



raising awareness among residents and businesses. The proposed objective is to create quieter, more livable urban environments that enhance the well-being of residents and support economic activity.

4. Promote clean transportation options: The document aims to promote low-emission modes of transport, including electric vehicles, by investing in charging infrastructure, offering incentives for purchasing and using these vehicles, and creating public awareness campaigns that highlight the benefits of clean transportation. The goal is to increase the adoption of low-emission modes of transport and reduce greenhouse gas emissions from the transportation sector.
5. Prioritize active mobility in urban planning and infrastructure: The paper aims to prioritize the needs of pedestrians, cyclists, and public transport users in all new development projects, and promote mixed-use development that supports compact and walkable neighborhoods. The proposed goal is to create a more livable, healthy, and sustainable city by providing safe and accessible pedestrian crossings, public spaces that prioritize active mobility and social interaction, and implementing traffic calming measures that reduce the speed and volume of cars on residential streets.
6. Reduce the number of personal cars on the road: The proposal points to reducing the number of personal cars on the road by promoting car-sharing, ride-sharing, and other alternative transportation options. The main goal is to create policies and programs that make car ownership less necessary and attractive, and provide affordable and convenient alternatives to car ownership. It also proposed incentives and subsidies for public transport users and active mobility commuters.
7. Promote sustainable urban logistics: It is aimed to promote sustainable freight transport options, such as electric delivery vans and cargo bikes, and create policies and programs that encourage the consolidation and optimization of urban freight movements. The proposed objective is to reduce the environmental impact of urban logistics, improve traffic flow, and reduce congestion in densely populated areas.

The proposed objectives are aligned with the expressed vision for a sustainable, inclusive, and efficient urban transportation system that prioritizes active mobility, promotes clean transportation options, and reduces noise pollution. It is needed to work towards achieving these objectives through a combination of policies, programs, and projects that support the well-being and prosperity of all residents in Montevideo.

3. Background – Where are we now?

3.1. Urban mobility context in Montevideo

Uruguay is geographically the second smallest country of South America and its population is estimated at 3.2 million people (INE, 2011). As its capital city, Montevideo is the most populated and largest city of Uruguay with 1.3 million people and an area of 201 square kilometers. Its metropolitan area includes other small cities that surround the capital and has a population of nearly 1.8 million people in total and 1,640 square kilometers.

Montevideo is located in the south of the country and has a coastline on the Río de la Plata, with an important natural port that provides connectivity with the rest of the world. The city has a humid subtropical climate with mild temperatures, cool winters and warm summers. The Cerro de Montevideo is the highest point of the city at a height of 134 meters and the city's average elevation is 43 meters. Like the rest of the country, Montevideo does not experience natural hazards such as earthquakes, hurricanes, ice storms, tsunamis or volcanic activity.

As for the economy, the main economic resources are agriculture, livestock farming and forestation. According to the World Bank, Uruguay's GDP in 2020 was 53.6 billion dollars, ranking it 82nd in the world. Uruguay has been a member of Mercosur since 1991 together with Argentina, Brazil and Paraguay, a South American trade bloc with headquarters in Montevideo.

In terms of GHG emissions, in 2020 Uruguay emitted 5,878 kt of CO₂, representing 0.02% of total global CO₂ emissions. The contribution of transport to the CO₂ emissions has increased significantly over the last decades, from 40% in 2000 to 60% in 2020. In 2015 Uruguay emitted 730 kt of CO and 76 kt of NO and NO₂, where transport accounted 42% and 38% respectively (EDGAR, 2022). With regard to noise pollution, Uruguay has a law that aims to prevent, measure and correct it, but this law has not yet been regulated (Rossini Iglesias, Gonzalo F., 2021).

Although air quality does not currently represent a problem in Uruguay, some established guide levels are exceeded showing a trend of steady increases in particulate material (CCAC, 2016). Beyond that, Uruguay is the top performer amongst developing economies in the Energy Transition Index (ETI) and one of the best positioned in the world. The ETI is a fact-based ranking intended to enable policy-makers and businesses to plot the course for a successful energy transition. The ETI (elaborated by the WEF) does not only benchmark countries on their current energy system performance, but also provides a forward-looking lens as it measures their readiness for the energy transition, air pollution and carbon footprint.

In recent years, Uruguay has undergone a transformation of its electricity grid, moving from an electricity system heavily dependent on fossil fuels to one based on renewable energies. More than 7,000 million dollars was invested in the transition between 2010 and 2016, and 97% of the electricity generation currently comes from renewable sources such as wind power, solar, hydro and biomass (UruguayXXI, 2019). In fact, in 2021, Uruguay was the country with the second highest share of wind and solar generation in the world with 35% (Figure 1, Our World in Data, 2022). Taking into account also that 100%

of the country’s population has access to electricity (World Bank, 2020), Uruguay is an ideal scenario for the development of e-mobility.

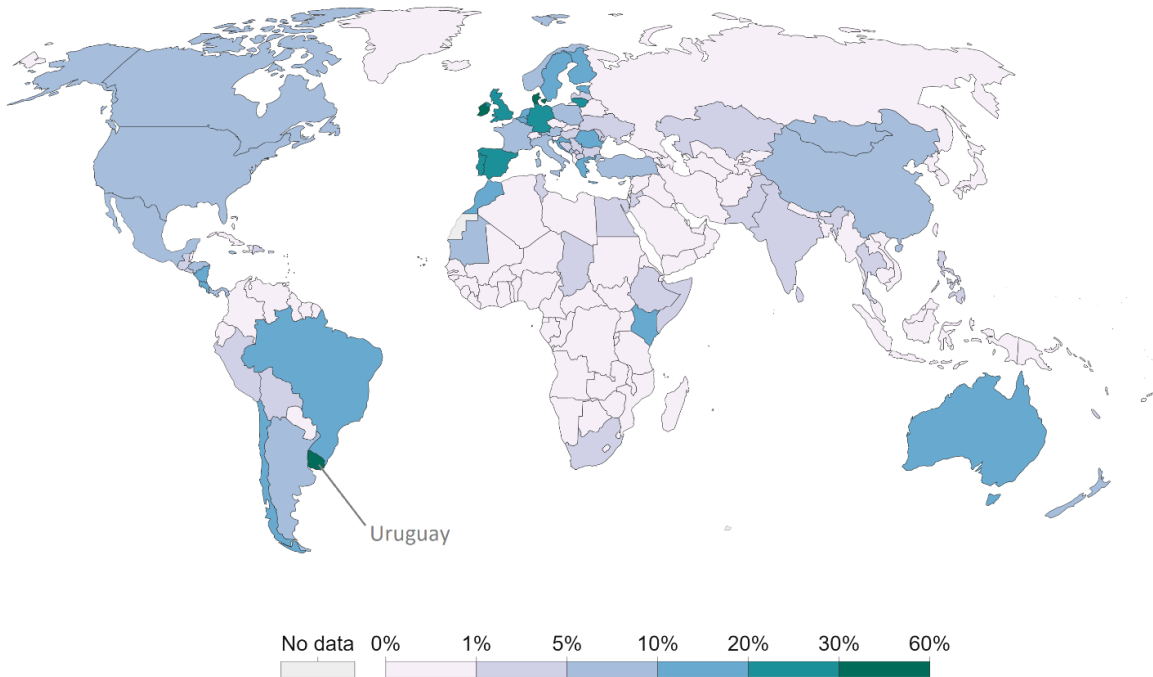

Figure 1 - Share of electricity production from wind, 2021. (Source: Our World in Data, 2022).

Uruguay’s total vehicle fleet in 2021 was 1,473,719 vehicles, of which 65% are cars and vans, 30% are motorbikes and the rest are heavy vehicles. In 2021 there were 3118 electric vehicles, of which 70% are motorbikes, tricycles and quadricycles (MIEM, 2022). According to the Continuous Household Survey, the number of cars increased by 17% from 2014 to 2018, while the number of motorbikes decreased by 12% (Guide for sustainable urban mobility planning in Uruguay, 2021). In fact, a 40% increase in vehicle fleet is projected from 2017 to 2035 (DNE-MIEM, 2020).

In Montevideo the highest number of travels occurs between 7 and 8 am, at 12 pm and between 17 and 18 pm. The public bus is the mode of transport with the longest journey time per trip, with an average of 42 minutes, while walking is the shortest mode of transport with an average of 12 minutes. In terms of distribution by mode of transport, 34% of trips are walking, 31% by car, 28% by bus and the rest includes trips by bicycles, motorbikes, taxis and others. The main reason for travel in Montevideo is for work, without considering return trips home and the average travel time by car is 20 minutes. In 2019, it was estimated that 630,000 people living in Montevideo traveled within the city to work and 90,000 people traveled from the Metropolitan Area to work in Montevideo (Montevideo Mobility Observatory, 2016).

In 2010 the Municipality of Montevideo (IM) published an Urban Mobility Plan that aims to implement an efficient, accessible and safe mobility model for people and goods. The Plan sought to improve transport modes, optimize the city’s road infrastructure and reduce fossil fuel pollution (Mobility plan – IM, 2010).



This plan is now obsolete and the IM is starting work on a new Sustainable Urban Mobility Plan for Montevideo.

The public transport system in Montevideo City is based on buses operated by four private operators, remises, taxis and ride hailing services such as Uber and Cabify. The Metropolitan Transportation System (STM), covers the entire metropolitan area of Montevideo and aims to incorporate the use of new technology, which allows more efficient, rational and safe public transport enabling greater practicality for users through routes and costs according to their needs. During 2007 and 2008 the use of public transportation increased about 30%, when a policy of subsidies was introduced, keeping prices low. However, cheap ticket prices were unable to curb steady car-use growth and since 2014 the ticket sales have even decreased slightly.

Montevideo city accommodates 140 bus lines that have 107 destinations and 4,721 stops covered by 1,528 buses. Every bus is equipped with a GPS satellite control system that allows tracking the route and location of all units, adjusting routes and schedules. Article 349 of Law No. 19,670 implements a subsidy meant to support the initial transition towards more efficient and sustainable technologies in the public transport of passengers by replacing up to 4% (four percent) of its country's total diesel-powered bus fleet with electrically powered buses, reaching by this a total of 32 electric buses (e-buses). Apart from that, there is a total of 107 electric taxis in Uruguay (MIEM, 2022).

In terms of bicycle use, according to the latest indicator published by the IM's Montevideo Mobility Observatory by September 2022, there is 53 km of bicycle infrastructure in Montevideo. Of this infrastructure, 11 km are bikeways (1.5 m clear width free for bikes on the street), 42 km are bike paths (a 1.5 m wide path on the sidewalk or similar) and 15 km on zone 30 streets (speed limit 30 km/h for all vehicles). Figure 2 shows the bicycle infrastructure present in the historic center of Montevideo and marks the location of the Terminal Ciudadela where one of the demonstration projects of the SOLUTIONSplus project will be developed.

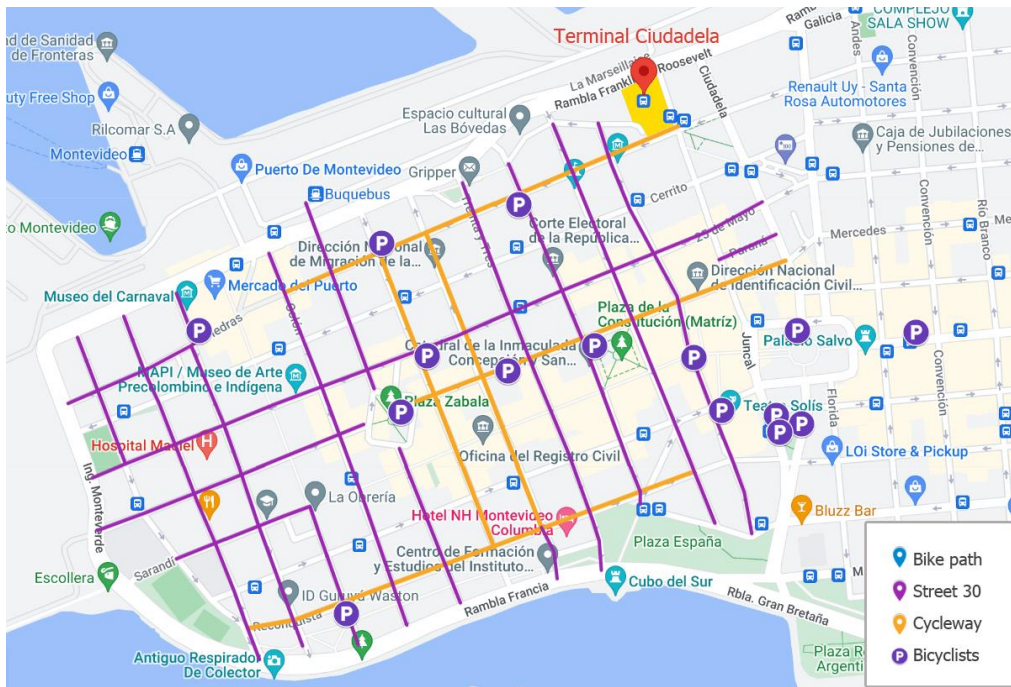

Figure 2 - Bicycle infrastructure in the historic center of Montevideo. (Source: IM website).

3.2. Current Policy Framework and Market Readiness for the deployment of e-mobility

A policy and regulatory framework for e-mobility is essential to promote the development of low-emission mobility. In the case of Uruguay, in recent years e-mobility has been promoted mainly through economic incentives for the purchase of electric vehicles (EVs). The main incentives and other policy measures that have been implemented in Uruguay to promote e-mobility are listed below:

- The Internal Specific Tax (IMESI by its Spanish acronym), an excise tax that owners have to pay when purchasing a vehicle (23-46% of the vehicle value for gasoline vehicles), was reduced in 2022 to 0% for all types of pure electric vehicles (Decree 390/2022).
- Since 2017 and for 5 years, vehicles powered only by electric motors are exempted from the global tariff rate (TGA by its Spanish acronym), a import tax corresponding to 23% of the vehicle value (Decree 325/017). The TGA is also exempted for the importation of lithium batteries and charging systems. In 2022, it was extended by five additional years, up to the year 2027.
- Electric utility vehicles were incorporated into the cleaner production indicator of the Investment Promotion Law (Decree 268/2020). The Investment Law (Law Nº 16.906) is a law that protects and promotes the investments in Uruguay, where it was established that a commission of application (COMAP) is the designated organism that sets the criteria for investment benefits. That law was amended in 2017 in order to include electric passenger vehicles within the investment eligible to obtain benefits. In that amendment, it was reduced from 10 to 4 years the

requirement to maintain ownership of these vehicles and rental companies were allowed to access the benefits of the investment law with the purchase of electric utility vehicles.

- Since 2015, the IM has launched calls for new electric taxis licenses at half the price of a traditional taxi license. With the money collected from the new licenses, it has subsidized the replacement of taxis from petrol to electric, reaching a fleet of 107 electric taxis. There will be incentives to incorporate 100 more e-taxis.
- From 1 November, the Ministry of Industry, Energy and Mining (MIEM) will give USD 5,000 to owners of taxis, remises and passenger transport app vehicles to change up to 100 vehicles from combustion to electric (“SUBITE passengers” programme).
- The approval of Article 349 of Law 19.670 (October 2018), which generates a subsidy to cover the difference in costs in the purchase of an electric bus compared to a diesel bus, for approximately 100 units for the entire country. The subsidy is destined to support the initial transition towards more efficient and sustainable technologies in the collective public transport of passengers by replacing up to 4% (four percent) of its fleet of diesel-powered buses with electrically powered buses. There are currently 32 e-buses operating in Montevideo and Canelones that were purchased using this subsidy.
- During 2018 the electric vehicle patent (annual tax) was reduced to zero (0) and later, in 2019, it was decided to leave it at 2.25% of the value of the vehicle, half of what a combustion vehicle pays. Also was implemented full liability insurances with promotional rates (BSE).
- Commercial discounts granted by the electricity company UTE for the increase of contracted power and in the electricity tariff (50% in UTE charging stations during valley hours and 50% in medium consumer tariffs and double residential tariffs during off-peak hours).
- The possibility to apply for energy efficiency certificates, an economic instrument of the MIEM for the energy efficiency measures carried out in which an economic retribution of 3-30% of the investment can be obtained.
- A month of free testing of electric utility vehicles for companies provided by MOVÉS project through its programme called “TuVe”. This programme ended on 5 September 2022 and was aimed at public institutions, organizations and companies that wished to test an EV in their normal operations and urban logistics. The vehicles were provided by EVs rental companies with which the MOVÉS project had signed an agreement.
- The SUBITE programme of the National Energy Directorate (DNE), which is a program that aims to incorporate e-mobility throughout the country. This project will support the purchase of 1000 electric motorbikes and 100 electric 3-wheelers. The programme also promotes the incorporation of 100 taxis, remises and mobile app transport services (Subite passengers).

Furthermore, the Uruguayan Government through its public companies UTE and ANCAP has built the ‘Electric Route’ that links the cities of Colonia del Sacramento (“in front” to Buenos Aires, Argentina) and El Chuy (on the Brazilian border) with charging points located every 60km. As it is shown in Figure 3 below, this route connects the east with the west of the country, including important cities such as the capital city Montevideo and the main seaside resorts. This infrastructure was the first “electric route” in Latin America, inaugurated in December 2017.



Figure 3 - Electric Route of UTE. (Source: Risso, Vignolo, Arismendi & Carriquiry, Faculty of Engineering 2020, p. 2).

After the construction of the electric route, a subsequent expansion of the recharging network was carried out by the aforementioned companies, currently reaching a network that covers almost the entire country, including all departmental capitals in the near future. A complete map of Uruguay's EV charging network is shown in Figure 4 below.

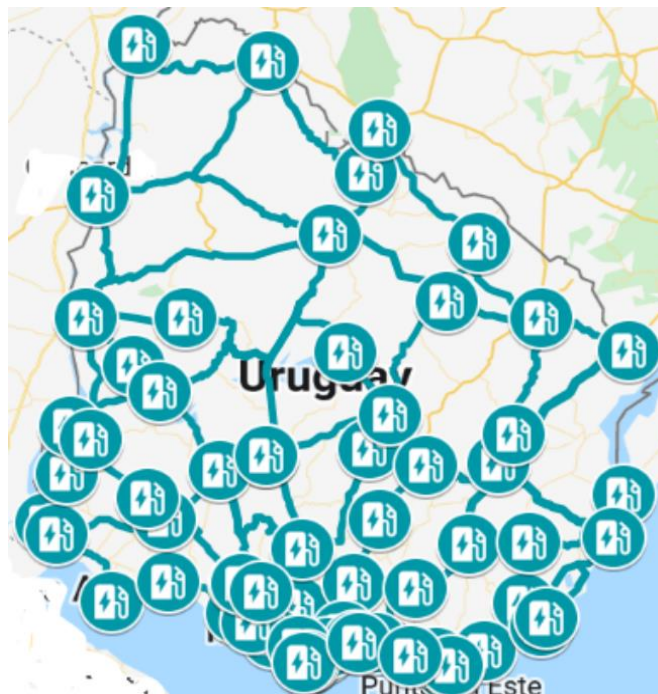

Figure 4 - Charging Network of Uruguay. (Source: presentation of UTE in Latam Regional Training 2022 SOL+ / GEF 7 September 2022).

In September 2017 the Global Environment Facility (GEF) approved the so called “MOVÉS” project, which aimed to establish an effective transition to an inclusive, adaptable, efficient and low carbon transport system. The MOVÉS project was executed by the MIEM between 2018 and 2022, together with the



Ministry of Housing and Planning (MVOT), the Ministry of Environment (MA), the International Cooperation Agency of Uruguay (AUCI) and UNPD as implementary agency. The project sought to facilitate the reform of the current framework of urban transport regulations and incentives, with a focus on public transport quality and promotion of non-motorized modes, the adoption of electric vehicles in the public transport and urban delivery sectors, closer cooperation among authorities and relevant agents and appropriate monitoring systems of transport GHG-emissions. Measures adopted included the energy efficiency labeling in light combustion vehicles and the introduction of EVs in public and utilitarian transport. The latter was done by promoting free testing of electric utility vehicles for companies with urban delivery operations with the aim of making known the benefits of these new technologies. The free trial lasted for one month and was carried out through rental companies.

Regarding public transport, in the framework of MOVÉS project, the MIEM and the transport operators signed an agreement of purchasing 30 e-buses (100,000 USD for each company as subsidy), (Presidency 2019b). As a consequence of the agreement and benefiting from the subsidy provided by law 19.670 for the purchase of e-buses, 30 electric buses were purchased in 2019, which started operations in June 2020. Among those 30 buses, 20 were supplied by the Chinese company BYD and 10 were supplied by the Chinese company Yutong.

One of the last plans of the MOVÉS project was the so-called “Green Fleet” plan (PFV) that sought to support companies with fleets dedicated to last mile delivery, urban transport and logistics operations in the process of changing their fleet towards a more efficient and sustainable solution. Its purpose was to support the analysis by the company of its operation and fleet with the replacement options of its vehicles for more efficient and sustainable options, and the incentives for this, provided by public and private institutions (already available in Uruguay) that MOVÉS brings together in the so-called Ecosystem for the Promotion of Sustainable Mobility.

3.2.1. Policy on climate change

In terms of national targets for the adoption of e-mobility, there are some normative precedents that set targets in this area. These include the targets set in the first NDC to the Paris Agreement and Uruguay’s long-term climate strategy. On the other hand, the Climate Plan of the Metropolitan Region of Uruguay should also be mentioned, a publication prepared within the framework of the project «Territorial Climate Change. Local Development Resilient to climate change and low carbon emissions in the departments of Canelones, Montevideo and San José”, Project URU/09/003 prepared by the three aforementioned Municipalities, together with UNDP.

On 3 November 2017 Uruguay approved by decree the first Nationally Determined Contribution (NDC) to the Paris Agreement. This first NDC sets out a series of targets to mitigate climate change by 2025 in Uruguay, in particular to reduce GHG emissions. In Uruguay, the energy sector is responsible for 95% of CO₂ emissions, of which the transport sector accounts for 51% (BEN, 2021), so Table 1 shows the NDC targets for 2025 that affect transport. The NDC differentiates between targets to be met unconditionally



and targets conditional on additional means of implementation that the country receives from other more developed states (financing, technology and capacity building).

Table 1 - Targets of Uruguay's first NDC to reduce CO₂ emissions in the transport sector by 2025.

Unconditional targets	Conditional targets
Implementation of mandatory energy efficiency labeling for light-duty combustion vehicles	Extension of energy efficiency labeling regulations for freight transport and public passenger transport
	Introduction of 110 e-buses and 550 e-taxis in public transport
Introduction of 15 e-buses and 150 e-taxis in public transport	Introduction of 900 electric utility vehicles
Introduction of 150 electric utility vehicles	Nationwide electric vehicle charging network (extending the Electric Route on the country's main roads)
Installation of the first Electric Route in Latin America, with chargers on national routes linking the cities of Colonia, Montevideo and Chuy	Installation of a DC fast charging network
	Replacement of 5% of the light private vehicle fleet with EVs
	Establish a vehicle testing laboratory for energy efficiency and gas emissions

According to the NDC Progress Monitor, there are 32 e-buses and 167 electric utility vehicles in Uruguay, so the targets set in the NDC for these vehicles have already been exceeded. As for e-taxis, there are currently 107 units, so with 3 years remaining, 71% of the target has already been reached. The Electric Route has already been built by UTE and is operational, while progress on energy efficiency labeling of vehicles is 50% complete.

On the other hand, in December 2021, the MA presented the Long-term Climate Strategy (ECLP by its Spanish acronym) prepared by the National System for Climate Change Response (SNRCC by its Spanish acronym), which is a guide for the elaboration of the next NDCs to the Paris Agreement by Uruguay. The ECLP sets ambitious but achievable future climate change targets in an aspirational scenario that would make Uruguay a carbon neutral country by 2050. In terms of road transport, the ECLP assumes the following milestones:

- By 2050 all motorbikes will be electric.
- By 2035 all new passenger vehicles will be zero-emission.
- By 2040 all new smaller capacity freight vehicles (gross vehicle weight less than 7.5 tonnes) will be zero-emission.
- By 2045 all new freight vehicles will be zero-emission.



The ECLP projects the penetration of zero emission vehicles by 2050 considering a trend scenario (according to local sales of zero emission vehicles) and an aspirational scenario (according to international estimates of the penetration of zero emission vehicles in the future), as shown in Table 2.

Table 2 - Trend and aspirational scenario projected in the Long-term Climate Strategy for the penetration of zero emission vehicles in the vehicle fleet.

Year	2019	2030		2040		2050	
Category	Current fleet	Trending	Aspirational	Trending	Aspirational	Trending	Aspirational
Cars & SUVs	672,660	1.4 % BEV	6 % BEV	13.5 % BEV	50.2 % BEV	49.6 % BEV	81.2 % BEV
Pick Up	159,453	0.7 % BEV	2.4 % BEV	6.2 % BEV	38.2 % BEV	40.9 % BEV	79.1 % BEV
Utility vehicles	59,665	4.3 % BEV	17.3 % BEV	29.6 % BEV	67.9 % BEV	72 % BEV	91.5 % BEV
Taxis	8,511	16 % BEV	16 % BEV	80 % BEV	80 % BEV	100 % BEV	100 % BEV
Buses	5,449	9.4 % BEV	11.2 % BEV/H2	30.5 % BEV	38.3 % BEV/H2	48.2 % BEV	100 % BEV/H2
Freight vehicles	54,906	0.3 % BEV	1.2 % BEV/H2	3.8 % BEV	17.6 % BEV/H2	22.7 % BEV	52.1 % BEV/H2

3.2.2. Existing regulations

Currently, there are several regulations that apply to e-mobility issues such as charging regulation, regulation on batteries, regulation on energy efficiency labeling and regulation on light electric vehicles (LEVs).

- *Charging regulation:*

UNIT IEC 61851-1: 2017 standard, year 2017. *“Conductive charging system for electric vehicles - Part 1: General requirements”*. This standard is the first part of the IEC 61851-1 series that specifies the general requirements for the supply of electrical energy for electric road vehicles. It should be noted that the vehicle and the EV power system are a complete system that is covered by a series of IEC and ISO standards. IEC 61851 covers the mechanical, electrical, communication, EMC, and performance requirements for the EV power system used to charge EVs, including LEVs.

UNIT 1234:2020 Standard, year 2020. *“Conductive Charging System for Electric Vehicles - Vehicle Tabs, Sockets, Vehicle Connectors and Vehicle Input Connections - Standard Formats”*. This standard establishes



a system of standardized formats for tokens, outlets, vehicle connectors and vehicle entrances for conductive EV charging.

Decree No. 225/2022 established that the power supply systems for electric vehicles (SAVE) must comply with the UNIT-IEC 61851:2017 standard and the connection elements with the UNIT 1234:2020 standard. In particular, Article 3 of Decree No. 225:2022 states that each public charging point shall have at least one Type 2 connector if AC charging, at least one CCS2 connector if DC charging, and all SAVEs installed at the same charging point shall offer similar charging powers.

Chapter XXX of the UTE Low Voltage Regulations added in February 2022 which sets out the requirements for installations for the conductive charging of EVs at both public and private level.

- *Regulation on batteries:*

There are not currently a regulations for lithium ion batteries or batteries for EVs in general. The Decree 373/003 (year 2003) regulates the handling and disposal of electric lead-acid batteries or accumulators for starting engines. That Decree is being updated to adapt it to the new battery technologies that EVs incorporate.

- *Regulation on energy efficiency labeling:*

UNIT 1130: 2020 Standard Energy Efficiency - Light Automotive Vehicles - Labeling, establishes the criteria for defining the performance of light vehicles and the characteristics of the energy efficiency label. This standard defines the criteria for efficiency labeling of internal combustion vehicles, pure electric vehicles, hybrid electric vehicles and hydrogen fuel cell vehicles.

- *Regulation on light electric vehicles (LEVs):*

Decree No. 37330/019 of the Departmental Board of Montevideo establishes requirements that LEVs and their users must comply with to promote road safety. Regulations include helmet use, mandatory safety equipment (brakes, rear-view mirrors, horn, lights and reflective waistcoat), seat belt use (if applicable), circulation and parking places, maximum speeds, registration requirement with the IM and driver's license. The Congress of Mayors also issued the circular N° 05/20 which adopts the same considerations for the circulation of these vehicles in the rest of the departments.

3.2.3. Policy and regulation gaps

However, policy and regulation gaps have been found in relation to supporting and expanding e-mobility in Uruguay. Some of these are which are listed in the following points:

- With regard to incentives for the purchase of EV: property tax rebate, waiver on tolls and parking, waiver on driving restrictions and environmental taxes rebate.
- With regard to energy efficiency: mandatory vehicles labeling system that reports their energy efficiency, as well as to define minimum efficiency standards.

- With regard to charging stations: define requirements for registration and qualification of installation companies.
- With regard to vehicle type-approval: safety requirements for locally manufactured EVs and retrofitted vehicles.
- With regard to last mile delivery: minimum percentages of EVs in delivery company fleets.
- With regard to vehicle scrapping: battery waste management and responsibilities (regulations) / legal obligation to eliminate vehicles (buses, taxis, trucks) after certain age of operation, dismantling and recycling centers, structured industrial sector for scrapping, dismantling and recycling vehicles and financial mechanisms incentivizing scrapping and recycling.

3.2.4. Business environment

There are several initiatives related to the academy from different universities and there are small and medium-sized enterprises (SMEs) and entrepreneurs who are carrying out initiatives related to e-mobility, EVs and batteries for EVs. Some of these startups are seen as very promising in terms of their future development possibilities and are working in a wide range of activities, from the production of different types of EVs, production of software, maintenance services, charging solutions and final disposal of batteries. Table 3 below contains the information on some companies that are currently involved in e-mobility projects in Uruguay.

Table 3 - Local start-ups working on e-mobility solutions.

SME Name	Type of activity
WheeLe	2 & 3-wheelers provider
CargoBike	e-cargo bike local manufacturer
GreenStar SRL	3 and 4-wheeler local manufacturer
Veems	LEVs provider
Trike	LEVs provider
Werba	Battery waste treatment
NAMI	EV retrofitting
eMobility Solutions	EV chargers supplier
Effiza	ESCO - EV charging infrastructure
Ecomoving	2 & 3 wheelers bikes

Finally, regarding e-scooters implementations, there were different e-scooter companies in Montevideo since 2018 such as LIME, Grin (Mexican company merged with local firm Mono), MOVO (Spanish company) and Scoot that were operating in Montevideo until May 2020 but they are not anymore operating in the city. There are other kinds of startups that are now working on e-mobility projects as it was shown in the table before.

3.2.5. Capacity building

According to the Training Needs Assessment (TNA) and given the context of the transition towards e-mobility in Uruguay, the main existing training needs are in infrastructure technologies, battery disposal, business, finance and fiscal schemes and mobility and integrated planning issues.

In terms of technology, infrastructure and network planning, much of the training needs of the local government are related to the EV technology, the use of the EV, spare parts and maintenance of EVs. As the technology is relatively new, there are basic questions regarding its operation under certain driving conditions and the range of an EV. More information is also needed on electricity cost and maintenance of the units as well as the battery replacement and final disposal. There are also some questions of users regarding the policies of the Authorities such as the price of the electricity in the near future.

In terms of business model development, the TNAs identified that there are very important needs in that regard. It appears that users and entrepreneurs need to know more about EV business, related costs and how to take advantage of the benefits (fiscal and non-fiscal) of e-mobility.

The TNA showed that the main obstacles in Montevideo that could slow down a transition to e-mobility are as shown in Table 4.

Table 4 - Main obstacles that could slow down a transition to e-mobility in Montevideo.

In the public sector	In the private sector:
Insufficient enabling policy and regulatory framework.	Limited maturity of technology / Lack of suitable technologies / Difficult supply of batteries and maintenance for batteries.
Limited financial means and high upfront investment cost for public actors.	Cumbersome maintenance (spare part availability or lack of after sales response).
Insufficient personnel in some key areas of the government.	Reticence from local commerce and/or delivery companies.
Limited knowledge and skills on e-mobility projects.	Limited financial means in the private sector and/or high upfront investment cost for these actors.
Public authorities are reluctant to decrease fuel tax revenues.	Lack of private actors initiating e-mobility projects.
	Lack of demand and limited knowledge and skills on e-mobility projects or business cases.

It was also identified that the biggest risks and negative impacts of a transition to e-mobility in Montevideo could be:

- Management of e-waste and battery recycling.
- Risks of new technology / new brands (lack of maintenance facilities, guarantee, not adaptable to the context and not equivalent to pre existing technology, short life of the battery or problems with charging standards).



- Increased demand for individual mobility if not combined with shared options and appropriate policies.
- Increased cost for local commerce and deliveries (in terms of electric tariff, battery maintenance or initial investment).

Apart from that, the highest needs for trainings were identified as:

- Charging infrastructure (including charging operation).
- EVs technology, maintenance and services.
- Operation of EVs.
- Examples of successful project implementation and business modeling.
- Logistics plan and delivery design systems.
- Integration in policies and plans.
- Finance and fiscal schemes.

A specific topic where Montevideo city has a need for training is the e-buses and e-taxis operations and logistics. For example: charging times and schedules, management of fleet, charging levels of batteries for e-buses and charge management from the point of view of the electric power distributor. Another important issue that would be needed to be the Municipality trained about is the electric vehicle battery management. A training program related to electric vehicle battery topics could cover the following items:

- **Introduction to Electric Vehicle Batteries:** This module would cover the basics of electric vehicle batteries, including their types, functions, and components, as well as the factors that impact battery performance and lifespan.
- **Battery Performance Testing and Diagnostics:** This module would cover the various tools and techniques used to test and diagnose battery performance issues, including how to interpret battery performance data and troubleshoot common battery problems.
- **Battery Reuse, Refurbishing, and Repurposing:** Repurposing or refurbishing used batteries can reduce waste and create new revenue streams for companies. Some potential repurposing options for used EV batteries include using them for energy storage in buildings or on the grid, powering off-grid applications like electric boats or RVs, and even powering electric bicycles or scooters. Refurbishing batteries involves replacing faulty or worn-out components to restore the battery's performance, while repurposing involves adapting the battery to a new use case. This module would provide an overview of the different ways used electric vehicle batteries can be repurposed, refurbished or reused, including the equipment and skills needed to refurbish batteries and the various repurposing opportunities available.
- **Battery Safety Considerations:** This module would focus on safety considerations related to electric vehicle batteries, including the risks associated with battery fires, and the safety protocols and procedures that should be followed when handling or transporting electric vehicle batteries.
- **Battery End-of-Life Management:** Once an electric vehicle battery reaches the end of its usable life, it needs to be properly managed to prevent environmental harm. Recycling is one of the most common end-of-life management options for used EV batteries. Battery recycling involves recovering valuable metals and other materials from the battery's cells, which can then be used



to make new batteries or other products. Other end-of-life management options include disposal in landfill sites or incineration, but these options have negative environmental impacts. This module would cover the environmental impact of electric vehicle batteries, including the various options available for the end-of-life management of used batteries, such as recycling or disposal.

Effective battery end-of-life management involves not only recycling or disposing of the battery, but also planning for the battery's end-of-life early on in its life cycle. This includes designing batteries with recycling or repurposing in mind, establishing efficient collection and transportation systems, and developing standardized protocols for dismantling, testing, and sorting used batteries.

The training program could be structured as a series of modules, each with its own set of learning objectives, assessments, and hands-on activities or simulations to help reinforce key concepts. The program could be also tailored to meet the needs of different audiences, such as mechanics, engineers, or technicians, and could be delivered through a mix of online and in-person training.

Finally, there are some local educational institutions that provide education and training on e-mobility topics which are presented in Section 4.1.

3.2.6. Key Stakeholders

The main stakeholders relevant to the issues concerning this roadmap are listed in Table 5. In one way or another, these stakeholders are involved in the transition to e-mobility in Uruguay.

Table 5 - Relevant stakeholders for Montevideo across the six stakeholder groups.

Stakeholder group	Organization Name and brief description
National / regional / local authorities	Ministry of Industry, Energy and Mining (MIEM) This Ministry is responsible for the energy issues. Within the ministry, it is the Energy National Directory (DNE) that is responsible for e-mobility (and also for the MOVÉS project).
	Ministry of Housing & Planning (MVOT) Is the Ministry in charge of spatial planning issues and housing. Until 2020 it has an environment unit that executed the MOVÉS project together with MIEM.
	Ministry of Transport and Public Works (MTOP) It is responsible for the development and planning of public infrastructure works in order to promote national development and the regulation of interdepartmental transport and long distance transport.
	Ministry of Economy and Finance (MEF) With respect to e-mobility the MEF has an important role to play as it is the one that formulates the decrees, stipulating financial incentives for e-mobility.

Stakeholder group	Organization Name and brief description
	<p>Ministry of Environment (MA) MA is responsible for national environmental policy in Uruguay. It was created in 2020, being before that date part of the MVOTMA. It is concerned with issues such as sustainable development, conservation of natural resources and environmental protection.</p>
	<p>ANCAP (National Administration of Petrol) Is a state-owned company in Uruguay. It is involved in the production of petroleum products, Portland cement and alcoholic beverages.</p>
	<p>UTE (Electricity Utility Company) Public company responsible for the generation, transmission, distribution and commercialization of electric energy, as well as providing advisory services and technical assistance in the areas of its specialty.</p>
	<p>Interinstitutional group of energy efficiency for the transport sector This group is made up of MIEM, MA, MTOP, MEF, IM, UTE and ANCAP, and since 2021 Ursea, Unasev and the Congress of Mayors also participate. The main goal is to avoid duplicating efforts, share information, formulate a shared vision for the transport sector and generate synergies. Some initiatives such as e-mobility plans on taxis and buses came out of this group.</p>
	<p>Municipality of Montevideo (IM) Is the local government of the capital city. It is the regulator of the public transport, and oversees sanitation and cleaning of the city and many more areas.</p>
	<p>MOVÉS project The Movés project was designed and implemented through the Climate Change Department together with DNE-MIEM. Its formal name is "Towards a sustainable and efficient urban mobility system in Uruguay". It was a GEF funded project that promoted sustainable mobility, being the UNDP the implementing agency.</p>
	<p>Consultative Council for Urban Transport (CCTCUM) This Council was established in December 2016 with the objective of improving the quality of the transport service in Montevideo.</p>
	<p>Congress of Mayors (CI) Its institutional objective is about the coordination of the policies of the regional governments.</p>
	<p>National Agency for Research and Innovation (ANII) Government entity that promotes research and the application of new knowledge to the productive and social benefit of the country.</p>
	<p>National Development Agency (ANDE) Institution that promotes the development through programs that seek to improve business and territorial competitiveness, with an emphasis on SMEs.</p>
Public transport company	<p>Compañía de ómnibus Pando S.A. (COPSA) PTO with 65% market share with 3 million tickets a month for routes that connect Montevideo with other important cities of the metropolitan area. This company does not operate inside Montevideo city.</p>
	<p>Compañía Uruguaya de Transportes Colectivos SA (CUTCSA) With 65% of the Montevideo market, it is the largest transportation company in Uruguay and the largest private operator in South America. In May 2020, 20 BYD electric buses were additionally incorporated on its fleet.</p>

Stakeholder group	Organization Name and brief description
	<p>Cooperativa de Obreros y Empleados del Transporte Colectivo (COETC) This Montevideo-based urban transit company launched a pilot project in August 2018 to test Yutong's ZK 6125 CHEVG diesel-electric hybrid model. In May 2020, 4 Yutong electric buses were additionally incorporated on its fleet.</p>
	<p>Unión Cooperativa Obrera de Transporte (U.C.O.T.) This is a Uruguayan passenger transport cooperative and provides services in the city of Montevideo. In 2020, three Yutong electric buses were incorporated on its fleet.</p>
	<p>Corporación Ómnibus Micro Este (COME S.A.) COMESA is a public transport company and has been operating since 1963 and has a fleet of 240 buses. In 2020, three Yutong electric buses were incorporated on its fleet.</p>
Passenger / individual traveler / consumer	<p>Umbrella organization of environmental NGOs The umbrella organization of all environmental NGOs in Uruguay.</p>
	<p>Uruguayan Center for Appropriate Technologies (CEUTA) Independent, non-profit foundation, created in 1985. Its mission is to disseminate, research and train in the use of appropriate technologies, generating alternatives that strengthen local communities by integrating social, economic and ecological aspects.</p>
	<p>Urban Cycling Self-Management Workshop (TACU) Cycling associations that seek to promote the use of the bicycle as an active means of transport, sharing experiences of own use and others to move safely and consciously in the city.</p>
	<p>Uruguayan Automotive Trade Association (ACAU) Non-profit Civil Association, duly constituted following current legislation and which brings together 22 companies representing and importing 50 brands (e.g. passenger cars, light utility vehicles, trucks and buses).</p>
	<p>UNiBiCi Unibici is an initiative that belongs to the University of the Republic (UDELAR) that promotes the use of bicycles among university students throughout the country for transportation to and between university premises.</p>
International cooperation and finance	<p>Uruguayan Agency for International Cooperation (AUCI) Among the tasks of AUCI are the planning, design, supervision, administration, coordination, execution, evaluation, monitoring and dissemination of international cooperation activities, projects and programs, received and granted by Uruguay, to comply with the national development priorities of the country.</p>
	<p>Development Bank of Latin America (CAF) CAF is a development bank created in 1970, owned by 19 countries - 17 of Latin America and the Caribbean, Spain and Portugal- as well as 13 private banks in the region. It will support financing solutions for SOLUTIONSplus cities in Latin America and is thus relevant for potential replication activities.</p>
	<p>Inter-American Development Bank (IDB) Established in 1959, the IDB supports Latin American and Caribbean economic development, social development and regional integration by lending to governments and government agencies, including State corporations.</p>

Stakeholder group	Organization Name and brief description
	<p>GEF Financing for the MOVÉS project, which is closely interlinked with the planned demonstration action, comes from the Global Environment Facility (GEF).</p>
Private business companies.	<p>There is a business sector in which companies that provide EVs participate, as well as recharging infrastructure, as well as services related to e-mobility.</p>
Academia/ Research	<p>Faculty of Engineering (FING) of the Public University Public institution of higher education in engineering of Uruguay.</p>
	<p>General Directorate of Professional Technical Education (UTU) Public institution focused on imparting learning that enables the comprehensive development of its students, responding to the wide variety of contexts, needs and interests, stimulating creativity and technical, technological, scientific and artistic innovation, and integrating learning to the diversity of the world. of work as a fundamental component of the educational process.</p>
	<p>Technological University of Uruguay (UTEC) Public university with a technological profile, oriented towards research and innovation. Committed to the strategic guidelines of the country, its objective is to make access to the tertiary university offer more equitable, especially in the interior of the country, promoting the collective construction of knowledge and the link with the productive sector to promote social, economic and technological development. .</p>
	<p>Electric Vehicle Work Group (GTVE) Research group on e-mobility that belongs to the FING which teaches a postgraduate course on the electric vehicle topic every year.</p>
	<p>Talleres Don Bosco Private educational center offering short courses and technical-professional secondary education. It has a short course specializing in hybrid and electric vehicles.</p>
	<p>Auto Libre Uruguayan company specialized in conversion of combustion vehicles to electric vehicles that also has an online course on retrofit.</p>

3.3. Demo project

The planned demonstration activities for Montevideo City includes two demo components:

- 1) Charging infrastructure for the Ciudadela terminal, which involves the construction of a multimodal charging hub for EVs that includes e-buses, taxis and LEVs.
- 2) Local manufacturing of 2- and 3-wheeler e-vehicles and renting schemes for these vehicles.



3.3.1. Component 1: Charging infrastructure for Ciudadela Terminal.

The Ciudadela Terminal is a hub for public transport located on the border of the Old City of Montevideo, near to the Independence square where the main avenue of the city (18 de Julio) begins and where the city tour bus starts its trip. It is also located near another public transport terminal called “Baltasar Brum” (also known as Río Branco Terminal), which is an interurban bus terminal.

The Ciudadela Terminal is owned by the Municipality of Montevideo used mainly by the four operators of urban public transport in Montevideo (COETC, COMESA, CUTCSA and UCOT). That terminal is also used by suburban public transport companies which are regulated by the Ministry of Transport and Public Works (MTO). The terminal is used by these companies as a destination for the lines and for refueling the buses and their overnight parking.

Currently, there are 30 electric buses (e-buses) operating in Montevideo since June 2020, that are distributed among the operators as it follows:

- CUTCSA: 20 units BYD with Type 2 connector
- COETC: 4 units YUTONG with GB/T connector
- COMESA: 3 units YUTONG with GB/T connector
- UCOT: 3 units YUTONG with GB/T connector

There are 3 fully electric lines (CE1, DE1 and E14) that depart and arrive at the Old City, creating the first electric corridor in the city on the "25 de mayo" street. This route is very close to the Ciudadela Terminal which makes it possible to coordinate the operation and recharge the e-buses during the operation (opportunity charging) or during the night as well. In the future, the lines that begin their routes in the Ciudadela Terminal could incorporate e-buses, increasing the number of e-buses that will use that charging station.

The aim of the first component of the demo project is to create a multimodal charging hub in the Ciudadela bus terminal, which will be able to charge e-buses and other EVs such as taxis and LEVs (e-bikes, 3 and 4 e-wheelers). Mainly, this component includes assistance with the construction of a high-capacity bus depot to charge the existing and planned e-buses overnight, taking advantage of the electricity oversupply and a reduced electricity price at night. The strategic location of the terminal also allows the installation of charging points for e-taxi providers and LEVs. This will integrate efficient and cost-effective smart charging solutions compliant with Combined Charging Standard (CCS) and Open Charge Point Protocol (OCPP).

A conceptual proposal for the remodeling of the Ciudadela Terminal and its surroundings was developed by a group of students of the master’s degree in urban design of the Technical University of Berlin (TUB), assisted by technicians from the IM and members of the SOLUTIONSplus project. The objective was the transformation of this space in the city, improving the urban environment of the terminal, air quality, road safety and the quality of life in the area. The elements considered include a comprehensive refurbishment of the Terminal, parking and charging spaces for LEVs such as bicycles and 3 e-wheelers, and charging

infrastructure for e-buses and taxis. The following figures show the conceptual proposal for the intervention at the Terminal Ciudadela designed by TUB.

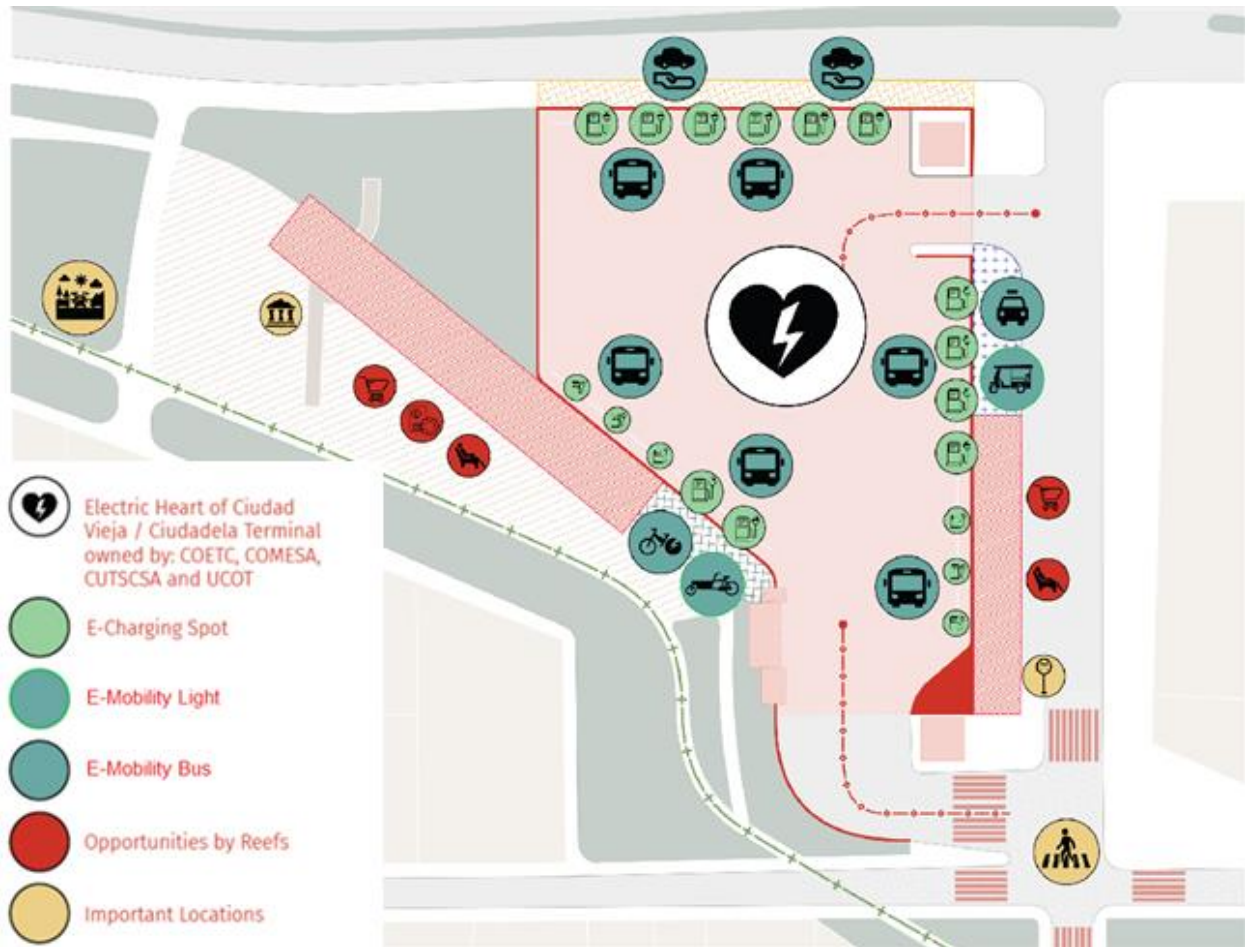

Figure 5 - Area view of the Ciudadela Terminal with the positioning of the different elements. (Source: Design studio of TUB).



Figure 6 - South view with the proposal for a linear pedestrian and active mobility park. (Source: Design studio of TUB).



Figure 7 - North view of the Terminal with the proposal for the location of different types of vehicles, chargers and infrastructure intervention. (Source: Design studio of TUB).

The proposal intervention in the Ciudadela Terminal consists of 2 parts which are developed below. Figure 8 shows a map of the stakeholders involved in the different activities of this component.

i) Consolidation of the multimodal hub:

- Remodeling of the bus stop, as the existing one is small and very deteriorated.
- Parking and recharging area for common and electric bicycles.
- Chargers for LEVs such as electric tricycles and quadricycles.
- Remodeling of the terminal pavement, as it currently has a deteriorated cobblestone floor that makes it difficult for low-floor buses to circulate. According to the final proposal of the IM, they will be executing a rigid concrete pavement instead of a flexible asphalt pavement. In order not to increase the expected costs of this intervention, it is proposed a main corridor of 8.0 meters wide instead of the 10.50 meters originally projected.

ii) Chargers for electric buses and taxis:

- Location of the chargers: it was proposed to incorporate the e-buses chargers on the inner side of the terminal and the taxi chargers on the outer periphery of the terminal.
- Specifications of the chargers: the chargers would be supplied, installed and maintained by the public electricity company (UTE). The chargers that UTE could have available are 2x60 kW, CCS-2 charger for e-buses and 1x43 kW Ecotap or similar charger for e-taxis.
- Operating model: like the public charging network, the e-buses chargers would be operated and maintained by UTE and incorporated into the network. The charging tariff is being analyzed considering to be set in a way that was attractive to the PTOs. Alternatively, taxi and LEVs chargers could be operated and maintained by a local private company.

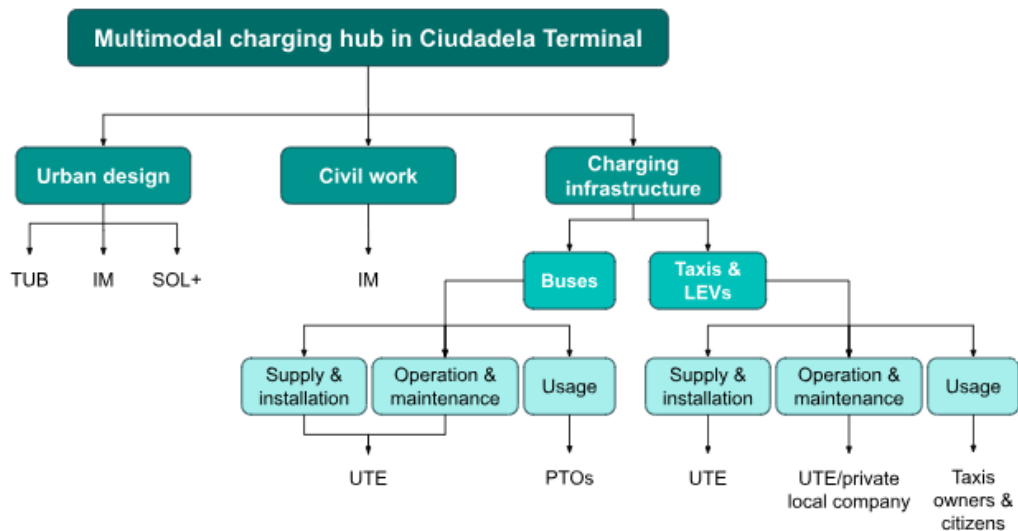

Figure 8 - Map of the stakeholders involved in the activities of the construction of a multimodal charging hub in Ciudadela Terminal. (Source: own elaboration).

3.3.2. Component 2: Local manufacturing of e-cargo bikes and e-cargo tricycles

This component involves: 1) local assembly of e-cargo bikes and e-cargo 3-wheelers, 2) rental scheme of the e-mobility solutions to ensure an annual profit for the owners, and 3) identification of potential long term users of these e-vehicle solutions. The local assembly will lead to the production of 8 e-cargo bikes, 2 e-cargo tricycles and 2 e-cargo quadricycles.

For this demonstration, SOLUTIONSplus in cooperation with MOVÉS launched a call for local manufacturers. The call for e-cargo bikes established a series of incentives for the local manufacturers and the start-ups awarded were Novas, GreenStar, Lasilasol, CargoBike and Wheele. However, only three companies continued to the prototyping and local manufacturing phase, a stage that was developed with the support of the Julio Ricaldoni Foundation. Figure 9 shows a map of the stakeholders involved in the stage of this component of the demonstration project and the different types of vehicles manufactured are described below.

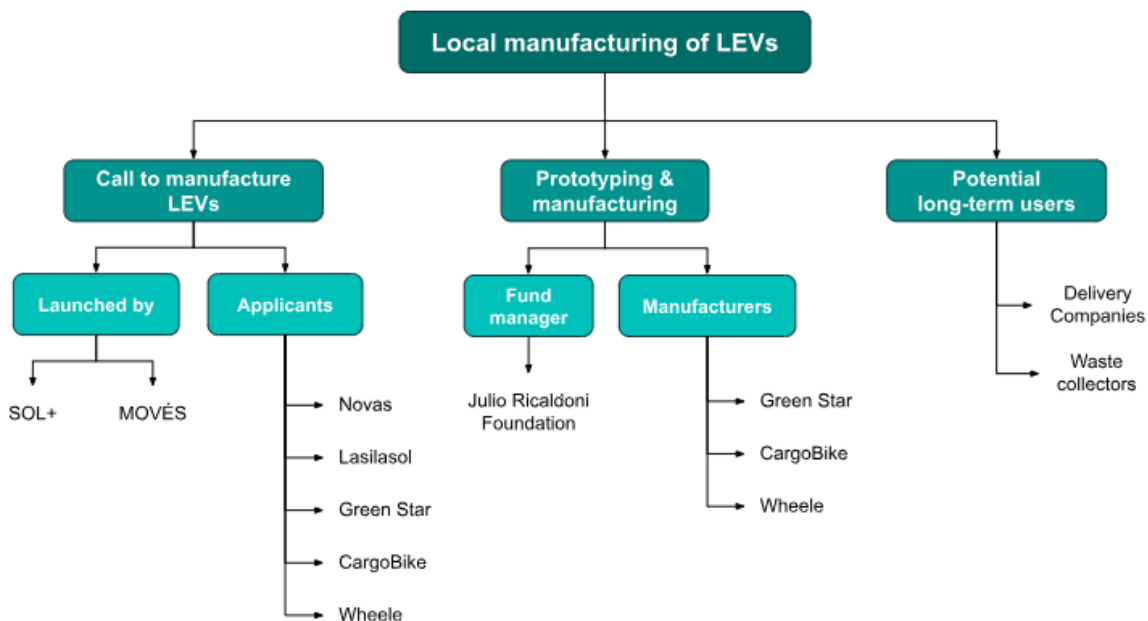

Figure 9 - Map of the stakeholders involved in the stage of the second component of the SOL+ demo project. (Source: own elaboration).

- E-cargo tricycles and quadricycles

Two electric 3-wheelers and two electric 4-wheelers are being manufactured by GreenStar in the context of the SOLUTIONSplus project, all of them powered by Valeo motors. The 3-wheeler has a load capacity of 200 kg while the 4-wheeler has a load capacity of 600 kg. Both models will have regionally assembled batteries, some manufactured in Argentina and another second life battery built and tested at the Faculty of Engineering of the UDELAR in Uruguay. Figure 10 presents the two different models of e-cargo tricycles that are being designed and manufactured.



Figure 10 - Example of e-mobility solutions for manufacturing in Uruguay: e-cargo 3-wheeler models designed and manufactured by GreenStar for demonstration under the SOLUTIONSplus project.

- *E-cargo bikes*

E-cargo bikes are being manufactured in the context of the SOLUTIONSplus project by two startups. In total, 8 e-cargo bikes will be produced and powered with different types of motors as follows:

i) Wheele is a conventional 3-wheels e-bike with a front basket and a rigid axle. It has a pedal-assist system without accelerator and a load volume of 300 liters. It will manufacture 3 units for the project.

ii) CargoBike is a conventional e-cargo bike with a rear motor and a central cargo basket. It also has a pedal-assist system without accelerator and the load area is configurable according to requirements. For the project, 5 units of the model “Long John” will be produced.

All the e-bikes are equipped with a 250 W power electric motor and a 10 Ah Li-ion battery. Figure 11 shows both models.



a)



b)

Figure 11 - Example of e-mobility solutions for manufacturing in Uruguay: a) electric 3-wheeler manufactured by Wheele and b) e-cargo bike manufactured by CargoBike for demonstration under the SOLUTIONSplus project.

- *Preliminary replication opportunities*

Home delivery is booming in Uruguay by several companies that provide food delivery and other kinds of non-food products on bicycles, motorcycles or tricycles. For that reason, suitable electric 3-wheelers or e-cargo bikes are a good option in order to provide a clean, safe, carbon free and efficient service. In this way, this second component of the demo project represents a solution for last mile delivery companies to introduce EVs into their fleets.

In particular, within the second component of the demo project, a pilot test will be carried out with a delivery company. In this test, the company will use a cargo bike manufactured by CargoBike and an electric 3-wheeler of Wheele for a duration of up to 4 weeks. Performance measurements will be made using the company platform (number of deliveries, times, etc.) and measurements of energy consumption



and vehicle performance will be made. The pilot also intends to conduct surveys and interviews with the drivers who will be using the vehicles and also with the recipients of the deliveries.

To ensure the adoption of locally manufactured EVs, the government should establish a minimum percentage of EVs in the fleets of last mile delivery companies and this value should be updated periodically until the entire fleet is electrified. Another aspect to keep in mind is not to provide too many incentives for the import of LEVs in order to avoid competition with locally manufactured LEVs. Care should be taken to ensure that it is not more profitable to buy an imported vehicle than a locally manufactured vehicle with similar characteristics. To encourage vehicle manufacturing, economic subsidies should also be granted for the importation of EV parts, such as batteries, electric motors, controllers, etc. In this regard, since 2017 and for 5 years, the importation of lithium batteries and charging systems are exempted from the global tariff rate (TGA). This benefit was valid until 2022, and it was extended for the following years.

The success in the demo project can be a good example to accelerate the electrification of transport in other cities in the country. Once the pilot has been carried out with a few delivery companies, dissemination campaigns could be carried out to convince other companies to use the locally manufactured vehicles. The vehicles could be used as last mile delivery vehicles in any city of the country to electrify this sector in other departments. In addition, they could also be incorporated into the fleets of the Departmental Governments (DGs), especially in the areas responsible for cleaning and waste collection in the cities.

One advantage that locally manufactured vehicles have over imported vehicles is that the companies that use them could become involved in the design process of the vehicles, providing feedback to the manufacturer to adjust the vehicle according to their needs. It is observed that the dialogue between user companies and local manufacturers would be more fluid than with foreign manufacturers, allowing the possibility of customized vehicles to be produced for the companies.

Finally, collaboration among different public organizations (Ministries, Academies and Federations) would be key in order to create replication opportunities. An inter-regional platform involving the different SMEs can also be established within the SOLUTIONSplus project to facilitate information and knowledge exchange. For example, Quito and Montevideo are conducting similar activities, and they are focusing on urban last mile freight, carrying out similar kinds of projects and prototypes.

4. Approach – Methodology and inputs.

The methodology used for the elaboration of the roadmap involved a literature review in which documents from Uruguayan governmental departments such as the IM and the MIEM were consulted. These documents include two planning guides for sustainable urban mobility and e-mobility in Uruguay, produced within the framework of the NUMP Uruguay project and financed by Euroclima+ and GIZ; the long-term climate strategy published by the MA; and similar documents produced by the governments of



Chile, Ecuador and Rwanda. Different publications of the MOVÉS project were also consulted, such as the analysis on the opportunities, challenges and regulatory framework necessary for the retrofitting in Uruguay published in 2022 and the document “Promotion of electric mobility in Uruguay”.

For data on GHG emissions, vehicle fleet, land use, modes of transport, electricity generation, etc., indicators published by government agencies in Uruguay were consulted, such as the National Energy Balance (BEN) of the MIEM and the Mobility Observatory of the IM. Regarding existing and planned charging infrastructure, data was mainly extracted from the website of the public electricity company UTE and the Presidency of Uruguay. A review of national decrees, laws and regulations was carried out to understand Uruguay’s current policy framework for e-mobility and the incentives provided by the government for the purchase of EVs.

Regarding the definition and description of the SOLUTIONSplus project components and their state of progress, several previous documents elaborated in the framework of the project were consulted. Regarding EV battery management, previous SOLUTIONSplus publications on battery reuse, refurbishing and recycling were also used as a reference. In addition, presentations made by the actors involved in the project to other organizations were also considered, in which the main themes of the project were described. As coordinators of the SOLUTIONSplus project in Uruguay, representatives of the Wuppertal Institute and UEMI reviewed the document and provided feedback with comments, which were considered in order to arrive at the final version of the roadmap.

An interdisciplinary workshop was held on 6 July 2022 at the Faculty Engineering of UDELAR in Montevideo and was attended by representatives of the MA, DNE, IM, UTE, the Julio Ricaldoni Foundation (FJR), the Wuppertal Institute, UEMI and Fier Automotive & Mobility (partner of the SolutionsPlus Project), a Netherlands based consulting and business development company specialized in zero emission mobility, logistics and road freight. The results of the workshop identify some current barriers to the adoption of electric vehicles and an action plan to address them, which was taken into account for the development of this roadmap. The findings show barriers in the areas of policy and regulation, replication and scaling up solutions, financing and business models and an action plan to address them, which was considered for the development of this roadmap. Table 6 shows the actions to be taken on these issues that emerged from the work of the workshop participants.

Table 6 - Main results of the workshop carried out among the SOLUTIONSplus project stakeholders, identified barriers to scaling up EVs and action plans.

Policy and regulation
Battery regulation and scrapping

Regulation of LEVs homologation
Regulation of EV charging service market
Approve the sustainable mobility commission
Approve the NUMPs and authorities in the interdisciplinary group (GIMS). Define a central authority to deal with e-mobility issues
Long-term planning and gradual perspective, sustainable mobility vision. Define clear and bold but realistic targets
Do not reinvent the wheel, learn from other countries and apply the best practices learned
Inclusion of stakeholders, listening to and accompanying all those involved
Supporting e-mobility with taxes and incentives. Electricity tariff for e-mobility
Replication and scale up
Success stories to showcase and spread
Community of practice for the dissemination and sharing of good practice
City integration. Conduct low-cost pilots in cities
Scaling up last mile logistics experiences with LEVs
Reduction of LEV manufacturing costs
Create a national DC fast charging network
Approve the SUMP

Multimodal vision of transport modes
National vision and agreement with local governments for e-buses
Cooperate internationally
Financing and business models
Role of banks in facilitating investments in EVs
Specific budget for sustainable mobility
Reformulation of incentives
Private banks considering “energy savings”
Leverage and collateral system for EVs
Tools that allow end-users (non-businesses) to archives the benefits of the rent rebate rate
Instruments for the replacement of e-buses
Restructuring of infrastructure investments in local settlements
Incorporate into other business plans
More specific calls for proposals to promote such incentives
Associative business models (innovate)
Promotion of the generation of freight infrastructure by the private sector
Think ahead for impact on tax-incentives



Some of the results of the workshop aim to the development of a charging ecosystem that accompanies and encourages the growth of EVs in the vehicle fleet. In particular, the need for a fast charging network to reduce the charging time, especially for long road trips, was identified. The development of a charging ecosystem is fundamental for the deployment of e-mobility, but it is equally important to have a regulatory framework on this issue. During the workshop, the need to regulate the EV charging system market, to have a specific electricity tariff for EV charging, to innovate in new business models associated with the charging ecosystem, among others, came up. Therefore, a focus area to be developed in this roadmap is the charging ecosystem. Section 4.2 describes some concepts that should be taken into account for the development of an EV charging ecosystem, mentioning aspects of standardization, regulation, business models and charging modes.

In terms of policy and regulation on e-mobility, the main outcome of the workshop was to identify the need to advance in the development of a regulation on EV batteries, on the homologation of LEVs and regulation on the charging ecosystem. Since one of the components of the SOLUTIONSplus project aims at the local manufacturing of LEVs and this roadmap aims at scaling up the use of these LEVs, it is relevant to develop these regulatory issues. The increase in the use of LEVs leads to an increase in the number of batteries that will enter the country, so it is necessary to have a regulation that ensures proper handling and adequate final disposal of batteries when they have reached the end of their useful life in vehicles. On the other hand, if the number of LEVs that will circulate on public roads increases, it is also necessary to have a regulation that establishes homologation requirements for these vehicles in terms of safety and circulation. Due to these results of the workshop that show a need to advance in regulation, e-mobility regulation is identified as a focus area to be developed in this roadmap. Thus, section 4.3 of the following chapter describes some regulatory measures that should be implemented for the development of e-mobility in Uruguay.

Another outcome of the workshop was the need to scale up experiences with the use of LEVs in urban last mile logistics and also to promote the use of these vehicles at the residential level instead of private internal combustion cars. For the deployment of LEVs, road infrastructure and urban planning must be in place to guarantee their safe coexistence with vehicles of other categories. In this way, section 4.4. develops some concepts that should be taken into account at the time of urban planning that favors the scaling up of the SOLUTIONSplus project components.

On the other hand, having technicians and professionals dedicated to providing e-mobility solutions is essential for the scaling up of EVs. Although progress in capacity building was not an outcome of the workshop, it was noted that Uruguay does not currently have a strong e-mobility training offer. In addition, in other bilateral exchanges with workshop participants, the need to advance in a dual education system on e-mobility has been identified. Thus, education and training is another focus area to be addressed in the roadmap. Section 4.1. develops this topic, outlining the main sectors to be trained in, and the relevant actors.

In September 2022, Module 3 of the SOLUTIONSplus 2022 Regional Training Programme was attended, in which organizations from Europe and Latin America and the Caribbean presented on charging



infrastructure for e-mobility. Some of the concepts learnt in the webinar were included in the content of the roadmap, mainly in the focus area of Section 4.2, dedicated to this topic.

Reference documents published by national and international organizations were used as inputs for the development of the roadmap, among which the following stand out:

- 4.1.** Two planning guides for sustainable urban mobility and e-mobility in Uruguay, produced within the framework of the NUMP Uruguay project and financed by Euroclima+:
 - 4.1.1. Guide to urban electric mobility in Uruguay.
 - 4.1.2. Guide for sustainable urban mobility planning in Uruguay.

- 4.2.** Two documents in terms of climate change policy:
 - 4.2.1. The first NDC of Uruguay to the Paris Agreement.
 - 4.2.2. The long-term climate strategy published by the MA.

- 4.3.** Similar documents produced by other governments:
 - 4.3.1. Proceedings of the first International Electromobility Forum Cuenca 2018 and proposed Roadmap for electromobility in Ecuador.
 - 4.3.2. National electromobility strategy in Chile.

- 4.4.** Publications of the MOVÉS project:
 - 4.4.1. Analysis on the opportunities, challenges and regulatory framework necessary for the retrofitting in Uruguay published in 2022.
 - 4.4.2. Promotion of electric mobility in Uruguay.
 - 4.4.3. Comparative study of the noise level generated by conventional and electric public transportation.

- 4.5.** Previous publications of the SOLUTIONSplus project:
 - 4.5.1. Demonstration implementation plans.
 - 4.5.2. Ciudadela Terminal multimodal node.
 - 4.5.3. Recycling plant for waste battery treatment.
 - 4.5.4. Refurbishing electric vehicle batteries.
 - 4.5.5. Repurposing electric vehicle batteries.

An important input for the elaboration of this roadmap was the collaboration of the counterparts involved. Among the government agencies that participated, the involvement of the IM, which collaborated by reviewing the contents of the document and making comments and contributions that were taken into account, stands out. In particular, periodic meetings were held with technicians from the Transportation Division in relation to the Ciudadela Terminal project and interviews were held with



technicians from the Mobility Planning Unit regarding urban planning and development of road infrastructure for the circulation of LEVs in Montevideo.

An interview was also held with technicians from the National Directorate of Climate Change of the MA to discuss issues related to Uruguay's climate change policy and the regulation on the management of batteries from EVs. A meet was also held with DNE technicians who provided comments on MIEM's projects on e-mobility.

With regard to the collaboration of local counterparts, meetings were held with technicians from the IM, the MA and the DNE. These exchanges led to comments and contributions to the roadmap focused on the areas of work of these agencies, which were taken into account in the preparation of the document. In particular, the participation of the IM in the review and feedback of the roadmap is highlighted.

After exchanges with the IM, technicians from the Mobility Planning Unit expressed their interest in having more information on the management of EV batteries, since the IM is concerned about the environmental management of this waste. Taking this into account and given that this roadmap promotes the use of EVs on a large scale, section 4.5. develops a focus area aimed at providing a basic introduction to the different processes that can be applied to an e-mobility battery after it has completed its first life in the vehicle.

5. The Roadmap – Where are we going?

5.1. Context

In recent decades, Uruguay has been working on a transformation of its energy matrix to become a more sustainable country, independent from the exterior and with lower GHG emissions to contribute to the fight against climate change. First, the transformation of the electricity matrix was carried out, moving from an electricity generation highly dependent on fossil fuels to a matrix in which 97% of the electricity generation comes from renewable sources. After this, Uruguay is beginning to take its first steps in the second energy transformation, since 38% of the energy matrix still continues to depend on fossil fuels (BEN, 2021). A large part of this percentage is due to the transport sector, so the government's mission is to decarbonize transport as one of the objectives to achieve the second energy transition.

In this sense, the government has set goals on the development of e-mobility in the country. Uruguay's first NDC to the Paris Agreement establishes as a goal the implementation of an energy efficiency labeling system for vehicles, the installation of an EV charging route and the electrification of a small number of vehicles in the fleet and public transport. Some of these targets have already been met and it is working on the second NDC, which will have more ambitious targets on e-mobility. The MA has also developed a



long-term climate strategy that proposes that all motorcycles should be electric by 2050, all new passenger vehicles should be electric by 2035, and all new freight vehicles should be electric by 2045.

To achieve these goals, the government has a vision to develop e-mobility throughout the country through a set of measures. Of particular note is the expansion of the charging network, to have 300 chargers by the end of 2023, of which 100 will be fast chargers. It aims to encourage the use of EVs in public transport by incorporating electric units in bus and taxi fleets. In particular, the government intends to have at least one e-bus in each department, for which it will implement a subsidy for each departmental municipality. One of the sectors that the government hopes to electrify is the last-mile delivery transport, for which it is promoting the free testing of EVs in last-mile urban logistics companies. In addition, the purchase of private EVs is also being promoted through economic incentives. The IM is also in the process of preparing a Montevideo Climate Action Plan, which addresses sustainable mobility issues and will be submitted for public consultation in 2023. For its part, the DNE is working on a guide for charging services in private places with public access.

In the context of this government position, this roadmap is a strategic document that aims to provide an input for Departmental Governments (DGs) in planning the transition to e-mobility. In particular, the document refers to two concrete demonstration cases on e-mobility. As mentioned before, one of these cases is the construction of a multimodal charging hub at the Ciudadela Terminal in Montevideo and the other is the promotion of local manufacturing of LEVs.

With regard to the Ciudadela Terminal component, the demonstration project is intended to be a pilot project that will generate the first experience in the construction of a charging hub of this type. From the work carried out, it is expected to collect data that can serve as background for the construction of other similar terminals in the future. The problems and considerations that arise from this stage will be base inputs to be taken into account in order to replicate the project with other terminals within Montevideo and in other department

On the other hand, e-mobility is relatively new, so there are many topics in which to research and innovate. There are numerous SMEs worldwide that are working on solutions in this area, so it is interesting to have national companies that are also finding solutions in e-mobility. In this sense, the second component of the demonstration project aims to support three national companies to manufacture 12 LEVs (3 and 4 e-wheelers and cargo bikes). The roadmap is intended to be an input for the DGs, suggesting a series of actions to be considered in order to establish a profitable LEVs manufacturing scheme in Uruguay. During the demonstration, data will be collected on the use of LEVs in last mile delivery applications, which will be used as input to study the incorporation of LEVs in urban logistics in Montevideo and other cities.

The two components of the demonstration project are intended to be used as successful examples of e-mobility solutions, to be replicated in other parts of the country. In the case of the locally manufactured vehicles, it is expected that demonstrations will be carried out with goods delivery companies, to serve as an example for the incorporation of EVs into the fleets of companies in this area. In addition, the fact that these vehicles are successfully used by companies can serve as a stimulus for citizens to also want to use



them. This not only represents an opportunity to decarbonize part of the transport sector, but also promotes the development of the national industry in the field of e-mobility.

Both components of the demonstration project aim at the transition towards clean and sustainable mobility. The creation of multimodal charging hubs such as the Ciudadela Terminal is both a necessity and a consequence of the electrification of collective public transport, and the local manufacture of LEVs aims to incorporate EVs in last-mile delivery to decarbonize this sector and provide a more sustainable and efficient option. Since almost all of Uruguay's electricity generation is renewable, it is a very comfortable scenario for the development of this type of project in which EVs can be charged with emission-free energy in their generation.

5.2. Specific objectives

This roadmap is a strategic document that aims to demonstrate the development of EVs as a scalable solution in Montevideo in the field of urban logistics in order to support the country to start the transition towards a low-carbon urban mobility and to comply with the Paris Agreement. It should be noted that the roadmap does not aim to define a national e-mobility strategy for Uruguay, as this process requires in-depth and coordinated work among multiple government agencies and stakeholders, but rather to provide basic inputs to facilitate the process of developing and planning a public e-mobility policy.

The document aims to boost e-mobility for both passenger and freight transport throughout the country. Although the geographical area included within the scope of the project is Montevideo City and its Metropolitan Area, which include some cities in the departments of Canelones and San José, the roadmap seeks to suggest how the demonstration project could be replicated in other urban areas of Uruguay.

This roadmap can be coupled with sustainable urban mobility measures that are planned in the coming years in Uruguay. In particular, the IM is starting to work on the development of a SUMP for Montevideo, so the roadmap is an input that can be used as a reference in the elaboration of such a plan. In this sense, the IM has collaborated as a counterpart in the development of this roadmap, making comments and sharing its needs for e-mobility projects.

In relation to the first component of the SOLUTIONSplus project, this roadmap develops measures to be considered for scaling up of the Ciudadela Terminal project to other terminals in Montevideo and other cities of the country. This promotes the transition of public transport to e-buses, contributing to the objective of electrifying 4% of the national fleet of public buses (approximately 140 buses), as established by Law 19.670.

On the other hand, the roadmap develops concepts for the scaling-up of the second component of the SOLUTIONSplus project, both by promoting a cost-effective domestic manufacturing scheme and promoting the insertion of local manufactured vehicles into the fleets of last mile delivery companies. In this sense, the roadmap is in line with the targets of the first NDC of Uruguay to the Paris Agreement and the Long-term Climate Strategy prepared by the MA, promoting the incorporation of e-mobility to help achieve the aforementioned targets in Section 1.2.1.





5.3. Timeline

5.3.1. Multimodal charging hub

Phase	Demonstration	Scale-Up	Mainstream
Timeline	2022-2023	2024-2029	2030 onwards
Target	<i>Planning and construction of a multimodal charging hub in the Terminal Ciudadela</i>	<i>Make public transport more attractive and install more multimodal charging hubs in other terminals</i>	<i>Electrify public transport in other departments and install recharging terminals throughout the country</i>
Finance	<i>SOL+, IM, UTE</i>	<i>IM, UTE</i>	<i>DGs, UTE</i>
Responsible	<i>IM, MIEM, MA, MTOP, UTE, public transport companies (COETC, COMESA, CUTCSA and UCOT)</i>	<i>IM, MIEM, MA, MTOP, MEF, UTE, Public transport companies (COETC, COMESA, CUTCSA and UCOT)</i>	<i>DGs, MIEM, MA, MTOP, MEF, UTE, Public transport companies in the country</i>
Actions	<p>Planning and analysis:</p> <ul style="list-style-type: none"> - Define the charging requirements of e-buses - Find a supplier for the chargers - Dialogue with public and private sector - Define operation model - Design the terminal and where the chargers will be installed <p>Infrastructure:</p>	<p>Planning and analysis:</p> <ul style="list-style-type: none"> - Define the business model/operation environment - Update the SUMP of Montevideo with an e-mobility perspective - Identify the main lines of buses to electrify - Plan the gradual electrification of the PT fleet <p>Infrastructure:</p> <ul style="list-style-type: none"> - Define charging solutions for the e-buses to be purchased - Identify charging needs of PTO 	<p>Planning and analysis:</p> <ul style="list-style-type: none"> - Begin introducing e-buses in the main cities of the country and then extend to the others - Identify the main bus lines by city and define which could be converted to fully electric lines <p>Infrastructure:</p> <ul style="list-style-type: none"> - Install chargers for the new electric fully lines - Consider installing renewable energy sources at terminals, such as solar energy.



Phase	Demonstration	Scale-Up	Mainstream
	<ul style="list-style-type: none"> - Installation of charging equipment for public transport - Installation of charging points for LEVs and e-taxis providers <p>Operation:</p> <ul style="list-style-type: none"> - Input related to e-mobility for the SUMP 	<ul style="list-style-type: none"> - Identify the main terminals with fully electric lines and install chargers at them <p>Regulation and normalization:</p> <ul style="list-style-type: none"> - Develop technical standards and regulations for chargers - Battery second life and recycling from e-buses - Regulate the interaction between the e-buses and electric grid <p>Incentives:</p> <ul style="list-style-type: none"> - Define a long-term financing mechanism to electrify the entire bus fleet - Support public transport companies and promote the e-buses purchase by subsidies for converting from fossil fuels - Plans to replace old buses with e-buses <p>Education and training:</p> <ul style="list-style-type: none"> - Generate comprehensive capacity building program related to e-mobility in all education levels - Training PTO in the use and management of electric fleets and efficient driving programs 	<p>Incentives:</p> <ul style="list-style-type: none"> - Define a long-term financing mechanism to electrify buses in each departmental of Uruguay



5.3.2. Urban logistics

Phase	Demonstration	Scale-Up	Mainstream
Timeline	2022-2023	2024-2029	2030 onwards
Target	<i>Local LEVs manufacturing pilots and demonstration of application cases</i>	<i>Cost-effective national manufacture of LEVs and promotion of their use in fleets of delivery companies</i>	<i>Intensive use of locally manufactured LEVs as last-mile delivery vehicles</i>
Finance	<i>SOL+, LEVs manufacturers</i>	<i>LEVs manufacturers</i>	<i>LEVs manufacturers</i>
Responsible	<i>SOL+, FJR, IM, LEVs manufacturers, last-mile delivery companies</i>	<i>IM, LEVs manufacturers, last-mile delivery companies</i>	<i>DGs, LEVs manufacturers</i>
Actions	<p>Industry:</p> <ul style="list-style-type: none"> - Local production of LEVs for urban logistics <p>Operation:</p> <ul style="list-style-type: none"> - Planning of on-the-ground e-urban logistics demonstration - Define the applications of the manufactured vehicles - Dialogue with the private sector in which the vehicles will be tested - Implementation of on-the-ground demonstration activities <p>Analysis:</p> <ul style="list-style-type: none"> - Analyze the data collection from the demonstration and identify the potential 	<p>Industry:</p> <ul style="list-style-type: none"> - Increasing local production of LEVs for urban logistic - Support SMEs and new business models - Consolidate collaboration with European providers <p>Infrastructure:</p> <ul style="list-style-type: none"> - Create cycle lanes and specific road infrastructure for micro-electro mobility <p>Communication:</p> <ul style="list-style-type: none"> - Dialogue with the companies to convince them for e-mobility uptake - Create agreements with local delivery companies to incorporate the manufactured vehicles into their fleets 	<p>Industry:</p> <ul style="list-style-type: none"> - Increasing local production of LEVs for urban logistic - Updating the manufactured vehicles considering new technologies and feedback from companies - Local production of chargers for the manufactured electric vehicles - Local assembly of battery packs <p>Communication:</p> <ul style="list-style-type: none"> - Dialogue with departmental governments and companies for locally manufactured vehicles uptake, promoting the results of the demonstration



<i>Phase</i>	<i>Demonstration</i>	<i>Scale-Up</i>	<i>Mainstream</i>
	<p><i>benefits for companies that will use the manufactured vehicles</i></p> <p><i>- Identify local companies that could adopt the use of the vehicles.</i></p> <p>Communication:</p> <p><i>- Communication campaigns showing the results of the demonstration</i></p>		

6. Implementation plan – How do we get there?

As a result of the workshop held in July 2022 and further bilateral exchanges with participating stakeholders, the need to address five main issues in the roadmap was identified. This section elaborates on these main themes in five focus areas: education and training, charging infrastructure, regulatory measures, urban planning and EV battery management.

6.1. Focus area 1: Education and training

As in other countries, the main training needs in Uruguay to develop e-mobility are in infrastructure technologies, battery disposal, business, finance and fiscal schemes, and mobility and integrated planning issues. Due to the fact that the technology is relatively new, there are not many local experts in the field who can guide and accompany the transition to e-mobility. For this reason, it is essential to develop training capacities in this field and to generate qualified professionals.

Beyond what has been achieved by the MOVÉS project and the IM, decision-makers are still uninformed. To scale-up e-mobility throughout the country, it is necessary to have a national training program in e-mobility for technicians of the Departmental Governments (DGs), which could be provided by international organizations with experience in the field. In fact, it is advisable to create a professional area on sustainable mobility within each DGs, where urban mobility issues are discussed. This area must have the authority to create SUMPs and work with other sectors of the DG's structure to ensure compliance with these plans. The area should be constantly updated to identify the main technology and business models in the future to prevent problems already experienced in other countries. The MIEM authorities are aware of these needs and that is why options such as IDB support or regional MOVE were sought through the Ministry of the Environment. For this purpose, the Euroclima+ project is being implemented. 6 municipalities are taking courses on sustainable mobility plans. In addition, work is being done with the IDB, UTU, INEFOP and the Uruguay-Germany Chamber of Commerce on a project for an Electromobility Training Center. On the other hand, through CEFOMER (UTEC, MIEM, INEFOP) electric mobility courses are being taught.

There is also a low number of mechanical workshops specialized in EVs maintenance to meet the projected demand for the next few years. Thus, it is necessary to create technical careers to train technicians capable of repairing and maintaining EVs. Technical careers should be based on a dual system of learning, in which a part of the knowledge is incorporated theoretically in the classroom and another part is learned practically in a workshop, applying the theoretical knowledge. In this regard, currently there are some courses and technical careers about e-mobility issues that are carrying out in Uruguay, such as:

- An introductory course on e-mobility carried out by the Renewable Energy Operation and Maintenance Training Center (CEFOMER) and the company E-Mobility Solutions. This course has

a duration of 20 hours and provides the basic knowledge about the current situation of e-mobility, technical aspects of EVs, their batteries and chargers, and new business models.

- The new Bachelor’s Degree in e-Mobility launched in August, 2022 by the General Directorate for Technical Professional Education of the National Public Education Administration, which is carried out by the Institute of High Specialization (IAE) in Las Piedras city, Canelones. This 1-year course aims to develop mastery of the functions of operation, installation and maintenance in relation to e-mobility as well as the diagnosis and correction of malfunctions in the operation of EV systems. The students of the course work with hybrid and electric motors in a dual way, with a theoretical part in the school and a practical part in a company of the sector. At the end of the course, the graduate will be able to continue working in the company where the practical part took place.
- A specialization course on hybrid and electric vehicles given by Talleres Don Bosco. The course aims to provide students with knowledge about electric energy applied to vehicles, technical aspects of powertrains, electric motors, batteries, charging systems, general aspects of body structures used for EVs and environmental sustainability. It is required to have a degree in automotive mechanics or prove knowledge on the subject. The duration of the course is 96 hours, with a quota of 15 people and a methodology consisting of 70% theoretical and 30% practical.
- An online course given by Auto Libre on electric vehicle design and conversion. The course consists of 7 online lessons in Spanish language, in which topics such as the design of the retrofitting of a vehicle to electric, components and systems of the EV, connection circuits of EVs and retrofitting procedures are addressed.

On the other hand, the public university of Uruguay (UDELAR) has carried out an annual 1-week e-mobility course since 2017, with the participation of foreign professors. In 2019 the course was implemented with the partnership of the Polytechnic University of Madrid (UPM). More specifically, two professors from the Automobile Research Institute (INSIA) and two professors from UDELAR taught the course which will be replicated in the following years. UTE (Electric Power Company of the Uruguayan State) and FEIBIM (Iberoamerican Federation of Mechanical Engineering) are both the sponsors of this activity. Figure 12 shows the current offer of e-mobility training in Uruguay, and as can be seen, it is limited.

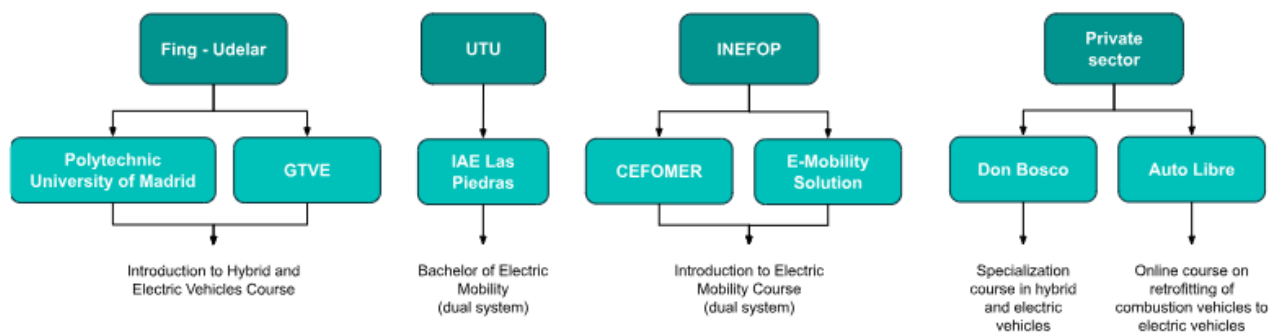

Figure 12 - Current offer of e-mobility training in Uruguay. (Source: own elaboration).

Universities need to develop professionals specialized in e-mobility, focusing on the implementation and maintenance of charging infrastructure, electronics handling and battery recycling. It is advisable to have at least a few masters in the field who have been educated in the best universities in the world. The academic sector should also promote research and development of local e-mobility projects, create working groups such as the Working Group on Electric Vehicles (GTVE) of the public Faculty of Engineering of Uruguay (Fing), and there should be collaboration and coordination between government and academia.

There is a technical cooperation project called "Innovative training for new jobs accompanying the sustainable energy transition" which aims to design and implement training modalities in the e-mobility sector to build technical skills. It seeks to improve the relevance of technical and vocational education (level II), higher vocational education (level III) and continuous training for the e-mobility sector in Uruguay. Therefore, curricula and teacher training should be improved, thinking of a dual educational system in which part of the knowledge is acquired in the study center and the other part by carrying out tasks in a company in the field. It is essential to have well-trained teachers to carry out the courses in which the e-mobility technicians will be trained. Teacher training can be provided by local and foreign experts and the Ministry of Education and Culture (MEC) via ANEP-UTU.

The project establishes the formation of a Coordinating Board with the participation of the DNE as coordinator, the General Directorate of Technical Vocational Education (UTU) as provider of technical education, the National Institute of Employment and Vocational Training (INEFOP) carrying out the continuous training programmes, and the Uruguayan-German Chamber of Commerce and Industry representing the private sector. This project is supported by the Inter-American Development Bank (IDB) who issued a call for a consultancy to carry out the following tasks:

- Identify and analyze the value chain of the e-mobility sector and ecosystem.
- Determine a qualification pathway based on competencies and skills, identifying occupational profiles in at least three lines of specialization (technician, middle management, supervisory technician) and in at least three links of the chain such as mechanical workshops, charging point maintenance and battery management.
- Identify and dimension the occupational profiles currently present in the chain.
- Identify new occupations that may emerge with the development of the sector and define the gaps that current occupations may suffer from.
- Define and implement actions to transfer the knowledge and methodologies necessary to replicate the process of elaborating new profiles in other areas of the sector to the counterparts involved.

For its part, the UTU is considering a future educational path for e-mobility at three educational levels as shown in Figure 13. In this pathway, the first level is the aforementioned professional bachelor's degree in e-mobility, which is currently offered at the IAE in Las Piedras City, then a tertiary technical course (CTT) in e-mobility, and finally a technologist in e-mobility. It should be clarified that of these three educational

levels, the only one that currently exists is the bachelor's degree in e-mobility, the other two levels will be implemented in the coming years.

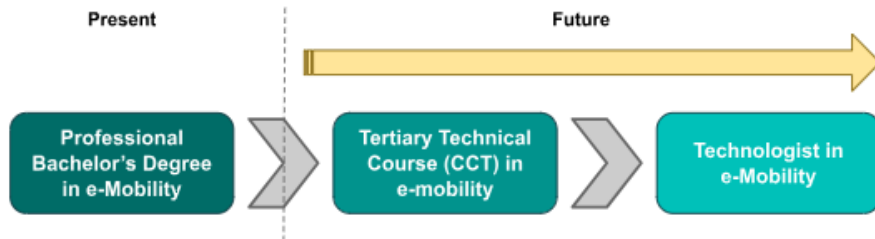

Figure 13 - Future e-mobility education trajectory considered by UTU. (Source: own elaboration).

On the other hand, the government provides incentives for research and innovation in e-mobility issues such as the provided by ANII through their specific tool FSE, and others. In this way, the government is supporting the SMEs that are already working and encourage the development and creation of new e-mobility projects. Electromobility business models development should be also supported. It was identified that there are very important needs in this regard, as users and entrepreneurs need to know more about the EV business, the related costs and how to take advantage of the (fiscal and non-fiscal) benefits of e-mobility.

Moreover, emergency, police and rescue personnel must be trained to work safely in accidents involving EVs. These workers must know how to handle EV parts in case of crashes and accidents to avoid injuries and fire hazards. This training could be provided by the Ministry of the Interior (MI), the Ministry of Transport and Public Works (MTO) and private local and foreign institutions. In this regard, in June 2021, a virtual training day was held for fire departments on how to deal with incidents involving EVs. Firefighters from the National Fire Department (DNB) were also trained abroad about accidents in electric vehicles. This activity was carried out within the framework of virtual workshops on e-mobility in Latin America and the Caribbean and was organized by the United Nations Environment Program, MOVE - Electric Mobility in Latin America and the Caribbean, Spanish Cooperation and Euroclima.

In addition, transporter and PTOs associations should be trained in the use and management of electric fleets (charging times and schedules, management of fleet, charging levels of batteries for e-buses and charge management from the point of view of the electric power distributor) and efficient driving programs. This training could be carried out by the MIEM, the MTO and the DGs.

Figure 14 summarizes what was mentioned in this focus area and shows an outline of the sectors that should be trained in Uruguay. It also mentions the training that would take place in each sector and the possible organizations responsible for the process.

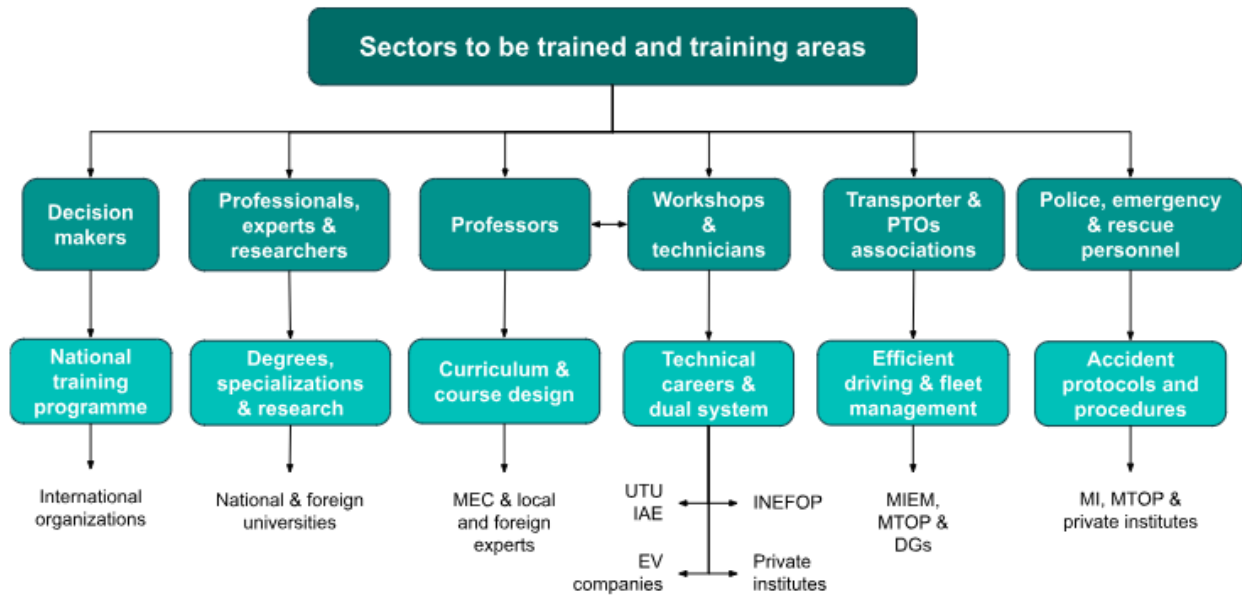

Figure 14 - Main sectors to be trained, areas of training, stakeholders and sources that could be in charge of training. (Source: own elaboration).

In addition to the training mentioned above, a not minor aspect necessary for the development of e-mobility is to educate citizens and companies about the importance of low-emission transportation. Currently, citizens are uncertain about buying an EV, mainly because they are distrustful about the performance of EVs on long distances and their safety aspects. To solve this, it is necessary to carry out awareness campaigns providing information and promoting success cases to demystify the use of EVs, such as the UTE electric fleet, e-taxis and e-buses operating in the Metropolitan Area, and the pilot EVs testing plans carried out under the MOVÉS project. Effective communication, marketing and awareness campaigns on the benefits of EVs should be designed and implemented to reach the most remote DGs from the Metropolitan Area. It is desirable that a sustainable urban mobility system is promoted in all departments of the country and that citizens are aware of its importance, so these issues could be included in road safety campaigns conducted in schools for example. A good opportunity to inform and sensitize citizens about e-mobility and sustainable urban mobility is when they decide to obtain their driving license. Basic information on EVs and the main aspects of sustainable urban mobility could be included in the theoretical test of this instance, promoting active mobility instead of the use of private means of transport.



6.2. Focus area 2: Charging ecosystem

Having an extensive public charging infrastructure is essential for the development of e-mobility in a city. In order for EVs to be introduced on a mass scale, the user must have clear answers to questions such as where and how the vehicle can be charged, what kind of chargers can be used for the charging, how to pay for the charge and how much it will cost, how long the charge will take and how many km can be driven on one charge, etc. These questions are also of interest to public transport operators and companies with electric fleets.

The development of charging infrastructure in a city is often seen as the chicken and egg problem. That is, what should happen first, should there be a large number of EVs to increase the number of charging points or should more charging points be installed to increase the purchase of EVs? From the point of view of this roadmap, the development of charging infrastructure is seen as a stimulus for the purchase of EVs. In this sense, the increase of charging points can be compared to an awareness campaign, because if citizens see that their city is filling up with charging points, they will feel more confident to buy an EV. In addition, it is possible that by seeing the deployment of charging infrastructure, citizens will become curious about e-mobility, learn about it and end up buying an EV.

It is important to note that without a charging network to meet the demand for EVs, it is not possible to scale e-mobility efficiently. Therefore, it is recommended that governments stay ahead of demand by installing chargers, in order to have the necessary infrastructure in place to support the increase in EVs that is projected for the coming years. In general terms, a technical/economic analysis must be carried out when charging points are to be installed. It should be defined what type of vehicles are to be charged, the time available for charging, where it is to be installed and the space needed for the infrastructure, and finally the budget available to the investment.

In a charging ecosystem interact the EVs' users, electric companies, chargers manufacturers and providers, government, e-payment companies, among others. The goal of a charging ecosystem should be to optimize the EVs user experience during charging and ensure interoperability in the system. To achieve this, all stakeholders must work together, but the government has a key role to play in the development of the public charging network, standardization and regulation of charging stations, which is expanded upon in Section 4.3 below.

6.2.1. Charging infrastructure in Uruguay

There are different types of charging infrastructure and charging solutions depending on where charging takes place, which are listed below. In order to ensure maximum flexibility for EV users to charge, all types of charging infrastructure are complementary and should coexist with each other.

- **Home charging:** charging is performed at the driver's residence. Generally, these are slow, low-power chargers, since more time is available for charging.



- **Work charging:** charging is performed at the driver's workplace. It has similar characteristics to home charging.
- **Depot charging:** charging of commercial fleets, buses or trucks. Slow chargers can be used due to the fact that fleets are stopped for a long time outside working hours.
- **Road-side charging:** charging in a public or private parking lot on the street within a city or urban environment. All types of chargers are used to complement or replace charging done at home.
- **Destination charging:** charging at the intended destination (shopping mall, restaurant, hospital, public institution, etc.), not including the workplace and home. Any type of charger is used, depending on the average length of stay at the destination.
- **Enroute charging:** charging is done on the route to the destination. Fast or ultra-fast chargers are used to provide charging in a few minutes during long-distance trips.

In the case of Uruguay, the charging infrastructure is limited with just over 150 public chargers in the country. While there is an electric route connecting the resort towns from east to west, there is no fast-charging network for charging buses, trucks and taxis. In order to have a nationwide fast charging network, it is necessary for the DGs to promote the installation of fast charging DC points in their territories to facilitate the users of EVs to recharge part of the autonomy in a few minutes, facilitating long-distance trips across the country.

In this regard, 23 DC fast chargers purchased by UTE arrived in the country in November 2022 and are expected to be installed by summer 2023. The chargers will have CCS2 and GB/T connectors and the planned investment for purchase and installation of the chargers is 500 thousand dollars. The equipment will be located in service stations and public spaces in each department according to agreements with DGs who are responsible for providing the land for the charging point and UTE is responsible for its installation and maintenance. Of the total, 11 chargers will be installed in the coastal area in the south of the country, 4 on the coast and 8 on the axis of the national Route No. 5. Specifically, 3 will be placed in Montevideo and one in each of the following locations: Shangrilá, Canelones, Durazno, Trinidad, Minas, Punta del Este, La Barra, Paysandú, Fray Bentos, Young, Rivera, La Paloma, Parque Santa Teresa, Rocha, Salto, San José, Paso de los Toros, Tacuarembó and Treinta y Tres. According to UTE, the number of fast chargers will double by 2023 and the charging network will reach a total of 300 charging points (Uruguay Presidency, 2022).

Figure 15 shows the geographical location of the charging points that currently make up Uruguay's charging network and Figure 16 is a zoom of the Metropolitan area. Both figures show in red the locations where approximately fast chargers will be installed.

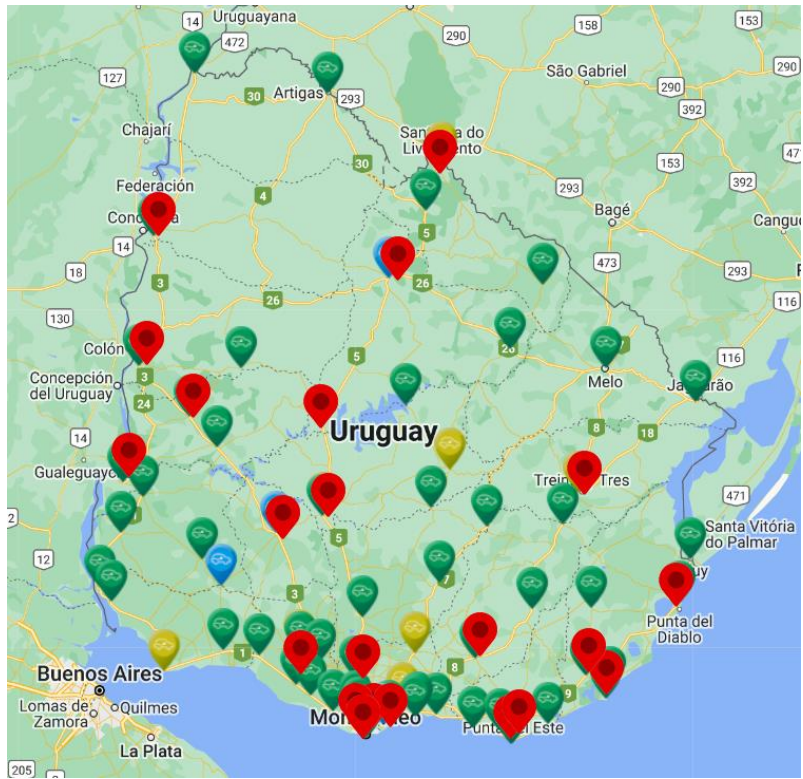

Figure 15 - Charging network of Uruguay. (Source: UTE website). The blue, green and yellow dots show existing charging points and the red dots show locations where fast charging points will be installed.

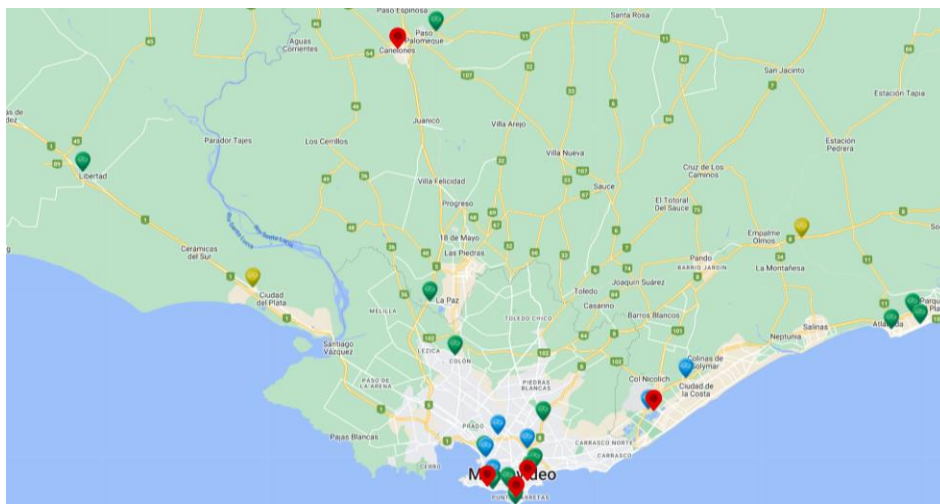

Figure 16 - Charging network in the Metropolitan area of Montevideo. (Source: UTE website). The blue, green and yellow dots show existing charging points and the red dots show locations where fast charging points approximately will be installed.

On its website, UTE has a section with information for EVs users, including a brief guide on how to charge EVs in the public charging network and at home, precautions for the correct use of charging points, a map of the charging network in Uruguay (Figure 15), types of connectors and the price of charging. With regard to the types of EV connectors currently marketed in Uruguay, Figure 17 lists the main types. For AC charging mainly the European Mennekes (Type 2) connector and the GB/T from China are used. The most common fast charging connectors in Uruguay are the European CCS2 and again the Chinese GB/T connector.

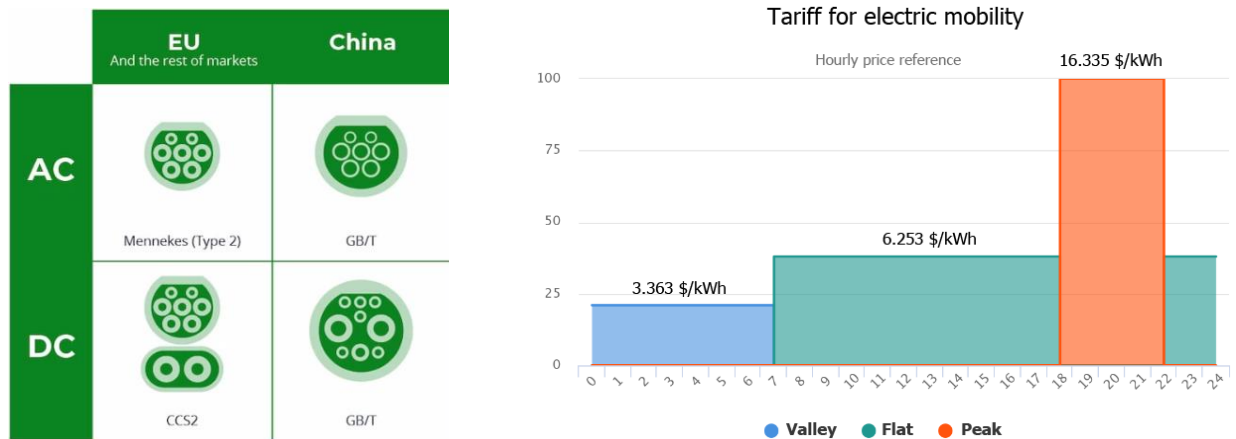

Figure 17 - On the left, main types of connectors used in Uruguay for EV charging. On the right, hourly evolution of the EVs charging tariff value. (Source: OVO Energy and UTE website).

In Uruguay, in order to charge an EV in the public network, it is necessary to have a card issued by UTE to pay at the charging points. Additionally, UTE is improving the charging experience for electric vehicles and it is now possible to pay for recharging with credit and debit cards at all points on the UTE Electric Route, through the UTE Mueve App. In all public charging points the applicable tariff is the one called by UTE as Electric Mobility Tariff, in which three different time slots are distinguished (valley, flat and peak) with different prices. Figure 17 plots the price of each slot as a percentage relative to the peak hour price and the cost in Uruguayan currency per kWh, according to UTE’s tariff schedule for 2022. During off-peak hours, the price of charging an EV is significantly lower than in other times (20% in valley hours and 38% in flat hours of the peak hour cost respectively), due to the fact that there is a surplus of energy generated with renewable sources during the early hours of the morning.

6.2.2. New business models

The national government and the DGs should develop regulations requiring the installation of chargers in shared-use buildings such as residential buildings, hospitals, state offices, education institutions and shopping centers. It is recommended to establish a minimum number of chargers to be installed in new buildings of this type. In this respect, there must be building requirements that provide for a space on the site for the installation of charging infrastructure.



The MIEM currently has energy efficiency certificates, in which monetary amounts are paid to companies that have carried out projects to increase their energy efficiency. The government could also establish similar incentives for new buildings to install charging points and renewable energy sources such as solar energy to complement the energy consumption of EVs charging.

With this deployment of chargers on private property, new business opportunities arise associated with EVs charging solutions. For example, every citizen who has the necessary space to place a charging point and charge a vehicle can become a charging host. In this way, new business models emerge in which citizens invest in the charging infrastructure and share part of their private property for EVs users to use their charger. If the host is an EV user, the charger could be put at the service of the community during the hours when it is not in use, so as to make more efficient use of the charging infrastructure. In addition, this represents a very interesting and convenient business model, in which all parties involved win. On the one hand, the host receives an extra income while the charger is not in use, and on the other hand, the community of EVs users also benefits from having more charging points.

There may also be business models in which the host only provides the physical space for charging, but the owner of the charger is another agent, which may be a company that installs, manages and maintains the chargers. In this case, the host would receive an income for making its physical space available and the company providing the charger would also receive an income for the use of the charger.

In both cases it is also necessary to have companies that carry out the data exchange between chargers to manage them and also manage the payment services for the charges. Therefore, the EV charging ecosystem represents a great opportunity for the development of new business schemes at several levels. In Uruguay there are already companies that are working to provide charging solutions based on these new business models.

Technicians from the National Energy Directorate (DNE) presented a regulatory guide for charging services in private places with public access. In addition, the government will prepare a proposal for a regulation that will establish a promotional period for private parties that install chargers on public roads to be exempted by UTE from the payment of power and fixed charges for 30 months - the beneficiaries will assume the cost of the civil work and connection for the charger (MIEM, 2022).

To ensure the interoperability in the charging of EVs, the central government must define a standard for charging points. Charger connectors and operating protocols should be established so that users can charge their EVs at any charging point. It is recommended that the standardization be carried out as soon as possible in order to reduce the number of different charges installed in the period in which there is no standard and to avoid redundant investments. Standardization should be carried out taking into account the EVs present in the Uruguayan market and global and regional trends. In Uruguay, there is the UNIT 1234:2020 standard that defines standardized formats for tokens, outlets, vehicle connectors and vehicle entrances for conductive EV charging. Decree No. 225/2022 was recently approved to encourage the use of Type 2 and CCS2 connectors, which is discussed in section 4.2.



Finally, one point to consider for the development of a charging ecosystem is battery swapping. This consists of charging the batteries of small EVs such as scooters, tricycles and quadricycles outside the vehicle. When the battery is discharged, it is replaced by a fully charged battery, which provides an “instant charge” of the vehicle. There are now companies in Europe that manage these kinds of batteries, with a number of battery exchange stations where users can leave their discharged battery and put a fully charged battery in their vehicle to continue their journey. It is recommended that the DGs support the development of this type of company in Uruguay, as well as vehicle sharing companies. In this sense, some projects of this type are starting in Uruguay, carried out by a private company that is working on the installation of lockers in the vicinity of a shopping mall, where users can exchange their discharged battery for a fully charged one and leave it charging in the locker. However, so far there is no business model associated with this project.

6.3. Focus Area 3: Regulatory measures

There are regulatory measures that the central government and the DGs can implement to promote the use of EVs. In fact, the regulatory framework plays a key role in the development of e-mobility and sustainable urban mobility. This section describes some regulatory aspects to be taken into account in different areas to promote the development of e-mobility. At the end of this focus area, a scheme summarizing some of the main existing and to be implemented regulatory measures to promote e-mobility in Uruguay is shown in Figure 18.

6.3.1. Charging infrastructure

One of the important points that the government should focus on is the standardization and regulation of EV charging points to ensure compatibility and interoperability. Uruguay has two standards that refer to charging point requirements:

- UNIT-IEC 61851:2017: Conductive charging system for electric vehicles.
- UNIT 1234:2020: Conductive charging system for electric vehicles - Standardized formats for plugs, sockets, vehicle connectors and vehicle input connections.

In this regard, in July 2022, Decree No. 225/2022 was published in which it is established that the power supply systems for electric vehicles (SAVE) must comply with the UNIT-IEC 61851:2017 standard and the connection elements with the UNIT 1234:2020 standard. In particular, Article 3 of Decree No. 225:2022 states that each public charging point shall have at least one Type 2 connector if AC charging, at least one CCS2 connector if DC charging and all SAVES installed at the same charging point shall offer similar charging powers. In this way, Uruguay is beginning to lean towards the use of Type 2 and CCS2 connectors, but the decree also allows the acceptance of connecting elements that do not comply with the UNIT 1234:2020 standard, as long as the standard of origin is indicated and an official Spanish version of the same is presented.



Furthermore, in February 2022, UTE added Chapter XXX to its Low Voltage Regulations, which establishes the requirements that EV conductive charging stations must comply with. The chapter establishes that any installation intended for EV charging connected to an AC or DC supply network must be designed and executed in compliance with the provisions set out in this document, which includes requirements related to the installation, safety for operators and users, maintenance, interaction with the network, among others.

6.3.2. Financing plans and business models

One of the main barriers to the purchase of EVs today is their high initial cost compared to an internal combustion vehicle of similar characteristics. Although the total cost of ownership of an EV is lower than that of a traditional vehicle, due to lower energy and maintenance costs, it is true that purchasing an EV requires a higher investment. It is estimated that the price of EVs will decrease over the next few years, reaching an initial cost comparable to that of a combustion vehicle. However, until this happens, the government and banks should encourage the purchase of EVs through financing plans accessible to citizens. In addition, with the promotion of e-mobility in each department in mind, a national budget could be created exclusively for sustainable mobility projects, which the DGs could draw on to achieve their e-mobility goals. Part of these funds could be financed from the proceeds of vehicle patents, for example.

An example of an economic incentive for the purchase of EVs is the "SUBITE" plan implemented by the MIEM, which provides a refund of up to 10% (with a maximum of U\$S 250) of the purchase price of electric motorcycles, and discounts on the electricity bill and insurance. There is also the "SUBITE passengers" plan, which provides an amount of U\$S 5,000 to the owners of taxis, remises and vehicles for transportation apps that purchase an EV.

Another aspect to take into account is the development of new business models based on the shared use of EVs, for example the hourly rental of LEVs. In this sense, the government should support this type of business, encouraging the creation of startups that provide solutions in this area. According to technicians from the IM's Mobility Planning Unit, they are currently working on a project for a public bicycle sharing system, in which a percentage could be electric.

6.3.3. Urban traffic and incentives

In the specific case of Uruguay, traffic and air quality problems are not as severe as in other countries, so it has not yet been necessary to establish measures to restrict the circulation of vehicles. However, in the last 20 years, Uruguay's vehicle fleet has grown considerably. According to data from the IM's Mobility Observatory, the number of cars registered in Montevideo annually grew by more than 70% between 2001 and 2018. This increase in the car fleet is starting to show traffic jams in some areas of the city at certain times of the day. In this context, it may be necessary to create measures to restrict traffic circulation in some areas of Montevideo and create a SUMP for the city.



In addition, the DGs are the bodies in charge of issuing vehicle licenses, and therefore have the power to adopt regulatory measures to control road traffic with environmental criteria. For these measures, the DGs could consider aspects of energy efficiency, pollutant gas emissions and the age of the vehicles to be registered. While in Uruguay there are economic incentives for the purchase of EVs such as those mentioned at the beginning of Section 1.2, the government should also promote e-mobility through non-economic incentives. In this sense, the DGs can define zero emission areas for example in historic city centers, tourist areas, parks or around hospitals and educational centers.

The DGs also must establish exclusive parking areas for EVs with chargers where they can be plugged in. The regulation should define the characteristics of these parking spaces such as the size and how they will be signposted. It may be useful to define the number of EV parking spaces as a percentage of the total number of available spaces, which should be updated as the number of EVs in the vehicle fleet increases. It is also necessary to regulate the actions to be taken in case such parking spaces are usurped by a non-electric vehicle and to give traffic inspectors the necessary power to act in such situations. In some cases, a timetable could be defined in which these parking spaces could be occupied by non-electric vehicles, which must be clearly indicated on site.

To stimulate the use of EVs, EV parking should be located in strategic locations in the city that really represent an advantage for drivers, such as in the downtown and commercial areas of the city. Montevideo has a tariffed parking area that covers the downtown area of the city, a total or partial exoneration in the tariffed parking of EVs could be implemented. In Uruguay there are tolls that must be paid when traveling from one department to another, so as a measure to stimulate the use of EVs, a partial or total exemption of these tolls for EVs could also be considered.

6.3.4. Noise pollution

At the national level, Law 17.852 was passed in 2004 with the objective of preventing, monitoring and correcting noise pollution situations, however this law has not yet been regulated. In its article N° 7, the law determines the competences of the DGs regarding noise pollution. Among other things, the law establishes the competency of the DGs to delimit noise protection zones and to apply the corresponding sanctions to violators of the departmental regulations (Gonzalo F. Rossini Iglesias, 2021). From the point of view of this roadmap, it is pertinent that each DG regulates noise pollution in its cities, based on the powers assigned to it by law.

In Montevideo, departmental regulations establish the prohibition of disturbing noises that affect the rest of the population or cause damage to the environment. In the case of noise from vehicles, the regulation establishes a limit of 88 dB for motorcycles, 85 dB for vehicles of less than 3.5 tons and 92 dB for vehicles over 3.5 tons. In addition, only vehicles with mufflers approved by the Mechanical and Electrical Installations Service of the IM are allowed to circulate on public roads. Failure to comply with these requirements may result in penalties and fines for vehicle owners (IM website, 2014).



However, there have been reports in the media that the noisiest point in Montevideo is 18 de Julio Avenue, where noise pollution levels are above international limits, with traffic being the main culprit (Subrayado, 2021). In relation to noise pollution produced by vehicles, as part of the MOVÉS project, a comparative study of bus noise levels was carried out in 2020, in which environmental noise measurements were taken inside the units and also of the noise generated by the buses in the environment in which they circulate. The study compares the noise levels of traditional diesel units and electric units, and measurements were taken in three scenarios: unit on but stopped, unit accelerating (0 to 25 km/h), unit at constant speed of 10, 20, 30, 40, 50 and 60 km/h.

As a result of the project, the electric units recorded lower sound pressure level values in all scenarios. The noise differences obtained between the electric and diesel units are very significant at low speeds below 30 km/h and converge as speed increases (when exceeding 50 km/h). However, according to data from the Mobility Observatory of the IM, the speed of buses in Montevideo is less than 30 km/h, so the perception of the difference in noise pollution associated with the change of technology would be very significant.

In relation to this, the need arises to classify areas of Montevideo based on their noise level and its relevance according to the characteristics of the place, since the admissible noise levels differ depending on whether there are hospitals, schools, parks, offices, industries in the area. In the noisiest areas, low-emission zones (LEZ) should be defined in which only active transport or EVs are allowed to circulate. This would not only increase air quality in those parts of the city but would also significantly reduce noise pollution in the area. LEZ are described in more detail in section 4.4.

6.3.5. Energy efficiency

In terms of energy efficiency, in Uruguay there is the UNIT 1130:2020 standard for energy efficiency labeling of combustion, electric, hybrid and fuel cell electric vehicles. However, there is still no regulation requiring labeling, but the MIEM is working to have this regulation approved before 2025. As a first step, it is recommended that the DGs require minimum energy performance standards (MEPS) for the public transport system and their official fleets, and then require MEPS for the importation and fabrication of vehicles in general.

For public transport, in addition to requiring MEPS, the DGs could start by requiring a percentage of e-buses in the fleet of each PTO, which would be increased in the following years. The same could apply to taxis and freight delivery vehicles. This could be done by continuing the subsidies and tax reductions for the purchase of EVs that currently exist for these sectors. An example of this exists in Montevideo, where only hybrid, electric, Euro 5 or higher buses are allowed - This is established in Departmental Digest Volume V, Transit and Transportation.



6.3.6. Governmental units specialized in e-mobility

It is highly recommended to create interdisciplinary units within the DGs' organizational structure to deal with e-mobility issues and a national working unit to articulate between the different DGs. There should be a permanent dialogue between the national government and the DGs to promote knowledge transfer and ensure coherence of regulatory measures at national and departmental level. A national e-mobility observatory could be created, which would provide clear and objective information on the development of e-mobility in the country and the world, which citizens could access to help them in their decision making. Part of the funds of the observatory and these units could be used for dissemination campaigns informing about the use and advantages of EVs, as well as the data collected by the observatory.

In Uruguay there is an Interinstitutional Group for Energy Efficiency in Transportation created jointly by the MIEM, MVOT, MA, MTOP, MEF, IM, UTE, the Congress of Mayors and ANCAP to discuss and generate proposals for efficient transportation. This group came up with initiatives to promote e-mobility such as the reduction of the IMESI tax, the incorporation of electric utility vehicles within the Investment Promotion Law, exemption of the TGA for EVs, incorporation of electric taxis and buses, etc.

There is also an Electric Mobility Roundtable (MME) created as a forum for government exchange with the main private actors in the transportation sector in order to promote the development of e-mobility. It also seeks to be a link between the public institutions that participate in the Interinstitutional Group on Transportation Efficiency and the private sector. The roundtable is led by the DNE and involves the Automobile Club of Uruguay (ACU), the Chamber of Automotive Industrialists of Uruguay (CIAU) and the Association of Automotive Dealers and Brands (ACAU). ASCOMA, AUDER, Chamber of Transport and now the Universities (public and private), UTU and UTE have joined to the MME.

6.3.7. Battery handling

Another very important area where regulation needs to be developed is in the handling of batteries in EVs. These batteries are replaced from vehicles when their capacity and power is reduced to 60-80% of the value at their BOL. Therefore, they have the potential to be used in less demanding applications such as stationary energy storage. In this sense, it is necessary to carry out a proper management of batteries, so there must be a regulation that requires importers and local fabricants of batteries conditions on second life, recycling and final disposal of them. An introduction to EV battery management methods is given in section 4.5.

There is currently a Decree 373/003 that establishes a regulation for management and final disposal of lead-acid batteries, which the MA is working on amending to include new battery technologies for e-mobility and stationary energy use. Some of measures that should be included in such regulation are:

- Require importers and fabricants of EVs to establish battery reception centers where users can return used batteries.
- Require registration with the MA for battery management and disposal.
- Penalties for treating batteries as any other type of ordinary waste.



- Create a labeling battery system to ensure the traceability of batteries.

6.3.8. Promotion of local manufactured LEVs

In recent years, several last mile delivery companies have set up in Uruguay, increasing the number of vehicles circulating in the city for this task. In most cases, the vehicles used for last mile delivery are motorbikes with combustion engines. In this sense, there is a great opportunity to electrify this transport sector by replacing these motorbikes with electric scooters or 3 e-wheelers. Therefore, the government should set a minimum percentage of the fleet of last mile delivery companies to be electric, which should be periodically updated and increased until the entire fleet is electric.

This can be linked to component 2 of the SOLUTIONSplus demonstration project in the sense that last mile delivery companies could electrify their fleet by incorporating locally manufactured LEVs. In order to foster the domestic LEVs industry and ensure a profitable ecosystem, care should be taken not to provide incentives to import similar vehicles that compete with locally manufactured vehicles and end up hurting their commercialization. Incentives should be provided to manufacturers to make their vehicles more competitive and cheaper than imported vehicles, for example by granting facilities and reductions in import taxes on parts and components used in vehicle assembly, such as batteries, electric motors, controllers, etc.

6.3.9. EV homologation

When importing or manufacturing a light vehicle, a homologation procedure must first be carried out at the National Directorate of Industries (DNI) belonging to the MIEM, while the process for trucks corresponds to the MTOP. This process must be carried out for new vehicles or when there is a change in the platform, chassis or model of the vehicle and the homologation has a duration of 2 years. The homologation procedure is detailed on the MIEM website where the documentation to be submitted is described, including a document citing the technical standard applicable to each element of the vehicle and the associated test reports.

It is noted that according to this procedure there would be no special requirements for the homologation of EVs, so it is suggested to verify that all components comply with international safety standards, especially the battery and its associated control systems. In addition, like all other vehicles on the road, EVs must comply with Law N° 19.061 which establishes road safety requirements. In particular, as far as this roadmap is concerned, Decree No. 37330/019 of the Departmental Board of Montevideo establishes requirements that LEVs and their users must comply with to promote road safety. Regulations include helmet use, mandatory safety equipment (brakes, rear-view mirrors, horn, lights and reflective waistcoat), seat belt use (if applicable), circulation and parking places, maximum speeds, registration requirement with the IM and driver's license. The Congress of Mayors also issued the circular N° 05/20 which adopts the same considerations for the circulation of these vehicles in the rest of the departments.



6.3.10. Retrofitting and homologation

The retrofitting of combustion vehicles to electric vehicles is an activity that emerges as an accelerator of e-mobility and as an option that promotes the circular economy in which already manufactured vehicles are reused, avoiding the need to have to manufacture the entire EV from scratch. In addition to reducing GHG emissions in the manufacture of EVs, retrofitting generates specific labor and increases the value chain of local industry with new business models. Furthermore, according to an analysis on the opportunities, challenges and regulatory framework of retrofitting in Uruguay published in the framework of the MOVÉS project in 2022, this activity provides greater equity to marginalized sectors of society, since the total cost of a conversion can be 1 to 3 times lower than the cost of buying a 0 km EV.

The government should simplify all the necessary procedures to convert a combustion vehicle to an EV to encourage the industrialization of this activity. Economic benefits can be provided to drivers to reduce conversion costs. In the case of France, for example, bonuses are granted for the retrofitting, provided that requirements are met in terms of the owner's income, annual kilometers traveled from home to work and minimum distance to work. There are also specific bonuses for retrofitting, provided that the process is performed by a qualified professional and certain requirements are met (MOVÉS, 2022).

It is of great importance that Uruguay advances in a regulatory framework on the retrofitting of vehicles from combustion to electric in which safety requirements for converted vehicles are established, before this activity increases. This regulation should establish, among other aspects, the technical conformity assessment scheme for vehicles and their components in accordance with current international standards and the processes for the approval of such vehicles. Another aspect to be taken into account in retrofitting is the final disposal of the parts, fluids and components originating from the combustion engine that are removed from the vehicle.

There is currently no law that expressly prohibits the manufacture, commercialization and registration of a converted vehicle. However, as with all other vehicles, vehicles that are converted must comply with national regulations that enable their circulation in Uruguayan territory. The following regulations must be complied with (MOVÉS, 2022):

- Law N° 18.191 - traffic and road safety in the national territory, in particular with articles from 28 to 33 that determine the characteristics of vehicles.
- Law N° 18.456 - regulation of the registration of motor vehicles, which determines the characteristics of the license plate of vehicles.
- Law N° 18.113 - National Road Safety Unit.

It is recommended that the concept of converted vehicle be defined in the vehicle classifications included in the regulations in particular in MERCOSUR/GMC/RES N° 35/94 Classification of Vehicles.

In a vehicle retrofitting project, the electrical power system must be designed considering the highest safety standards. Fuses, overcurrent circuit breakers, inertia switches, Battery Management Systems (BMS) and intercommunication between components must be used. These components must have product certification where applicable.



According to the MOVÉS publication on retrofitting, internationally there are two methods to enable the commercialization and circulation of a vehicle, one is homologation and the other is self-certification. In the case of self-certification, it is the manufacturer itself who ensures that the vehicle, components and systems comply with the requirements established by the regulations. In the case of homologation, on the other hand, an accredited technical service is in charge of carrying out tests to check that a vehicle and its components comply with the regulations. In the USA, self-certification is used, while in Europe the homologation process is used, which involves three parties: the manufacturer, the accredited technical service and the homologation authority. Generally, the procedure involves an audit of the manufacturer to demonstrate that it has the capacity and technical competence to manufacture the vehicle. Then the accredited technical service takes a vehicle from the manufacturer to be evaluated and verifies its correspondence with the technical description provided by the manufacturer. In addition, the technical service evaluates by means of tests the compliance with the corresponding regulations. Based on the results of the tests and the evaluation of the product by the technical service, the approval authority issues an approval certificate certifying that the vehicle complies with the regulations. Generally, after this initial evaluation to obtain homologation, periodic checks are carried out on vehicles on site to ensure their correspondence with the vehicle originally tested.

In general, in the automotive industry, type approval schemes are used to evaluate the conformity of both vehicles and their components. A representative sample of the product "type" is taken, evaluated and tested to determine its conformity with the corresponding regulations. Similar schemes can be implemented for the conformity assessment of retrofitting vehicles and their manufacturing processes to maintain quality standards in high volume production. This will require the existence of verification and validation bodies that work with the evaluation of converted vehicles in Uruguay and a governmental authority in charge of granting retrofitting and circulation permits for those vehicles.

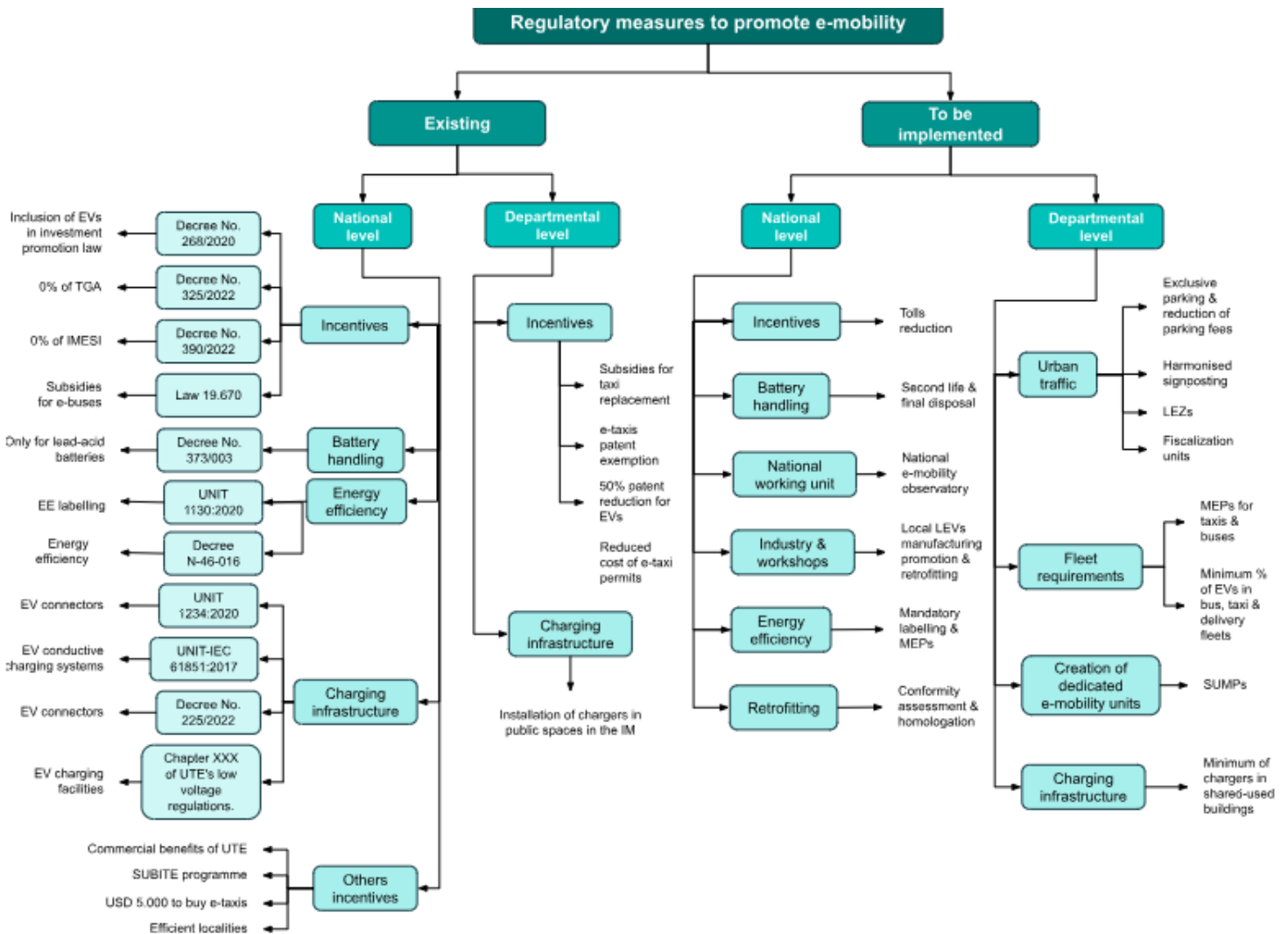

Figure 18 - Existing and to be implemented regulatory measures for the promotion of e-mobility in Uruguay. (Source: own elaboration).

6.4. Focus Area 4: Urban planning

Urban planning has a very important role to play in the development of e-mobility in cities. On the one hand, urban planning is needed to design and create new infrastructure for the circulation of LEVs such as bicycle lanes and cycle paths, while on the other hand it is also relevant to plan the deployment of the charging network in the city. Considering these two concepts, urban planning is directly related to the two demonstration components of the SOLUTIONSplus project as described below.



- *Related to charging infrastructure and space use:*

The first component refers to the construction of a multimodal charging hub at the Ciudadela Terminal, where charging of buses, taxis and LEVs will be possible. In this sense, some considerations to be planned are: how the work will be carried out, how the traffic and the urban environment of the area will be affected during the construction, how the bus lines operating in the terminal will be affected, and the potential impact on road circulation once the terminal is operational. With a view to the future scaling up of the works carried out at the Ciudadela Terminal to other bus terminals, these aspects should be taken into account in the planning of projects at any other terminal in the country. In addition to loading buses, the terminal will allow the charging of taxis and LEVs, so it must be planned how these vehicles will access the charging points and how they will be physically arranged in the terminal to avoid obstructions and difficulties in the circulation of other vehicles and pedestrians.

As mentioned above, the use of EVs can be promoted with non-economic incentives such as exclusive parking for EVs in strategic areas of the city, exemption from parking fees, delimitation of low-emission and low-noise zones in which only active mobility and the circulation of EVs is allowed. In this regard, according to exchanges with technicians from the Mobility Planning Unit of the Municipality of Montevideo, the implementation of exclusive parking for EVs is being permanently evaluated. The IM also intends to exempt EVs from parking fees, a measure that would be gradually reversed as the number of EVs increases.

A dense network of chargers in the city is very important for the development of e-mobility. In many cases, such chargers must be installed on departmental government-owned land, so the DGs must take this into account in urban planning. For its part, the IM is collaborating with UTE to install more chargers on its property.

Regarding the delimitation of low emission zones (LEZ), the IM confirmed that this is one of the topics included in the Climate Action Plan that they are developing. They are evaluating starting with an LEZ in the Old City of Montevideo and also implementing a traffic calming zone in the Cordón neighborhood.

- *Related to LEVs scaling:*

On the other hand, the second component refers to the local manufacture of LEVs and the incentive to use them for last mile delivery. The world of LEVs is very diverse, with various types and configurations, so it is necessary to establish traffic criteria that allow for proper coexistence among them, with vehicles of other categories and with pedestrians. Therefore, the DGs will have to plan exclusive traffic lanes for these vehicles to allow their safe circulation.

In Uruguay there are four types of road infrastructure for bicycle traffic, which differ in terms of road hierarchy, type of pavement, minimum width, type of separator, among others. These types of infrastructure are listed below and are represented graphically in Figure 19.

- Zone 30: all vehicles coexist on the street with a maximum permitted speed of 30 km/h.
- Protected bicycle lane: lane exclusively for bicycle use, delimited from the rest of the street by a physical separator.
- Bicycle lane without physical separator: lane exclusively for bicycle use, marked only with paint on the street.
- Bicycle path: exclusive lane for bicycle use on the sidewalk.

On roads where the speed limit exceeds 45 km/h or have a high vehicular flow, bicycle infrastructure requires physical separators. On the other hand, on neighborhood roads with low-speed traffic, it is possible to use 30 zones with adequate signage, where all vehicles share the roadway (NUMP, 2021).

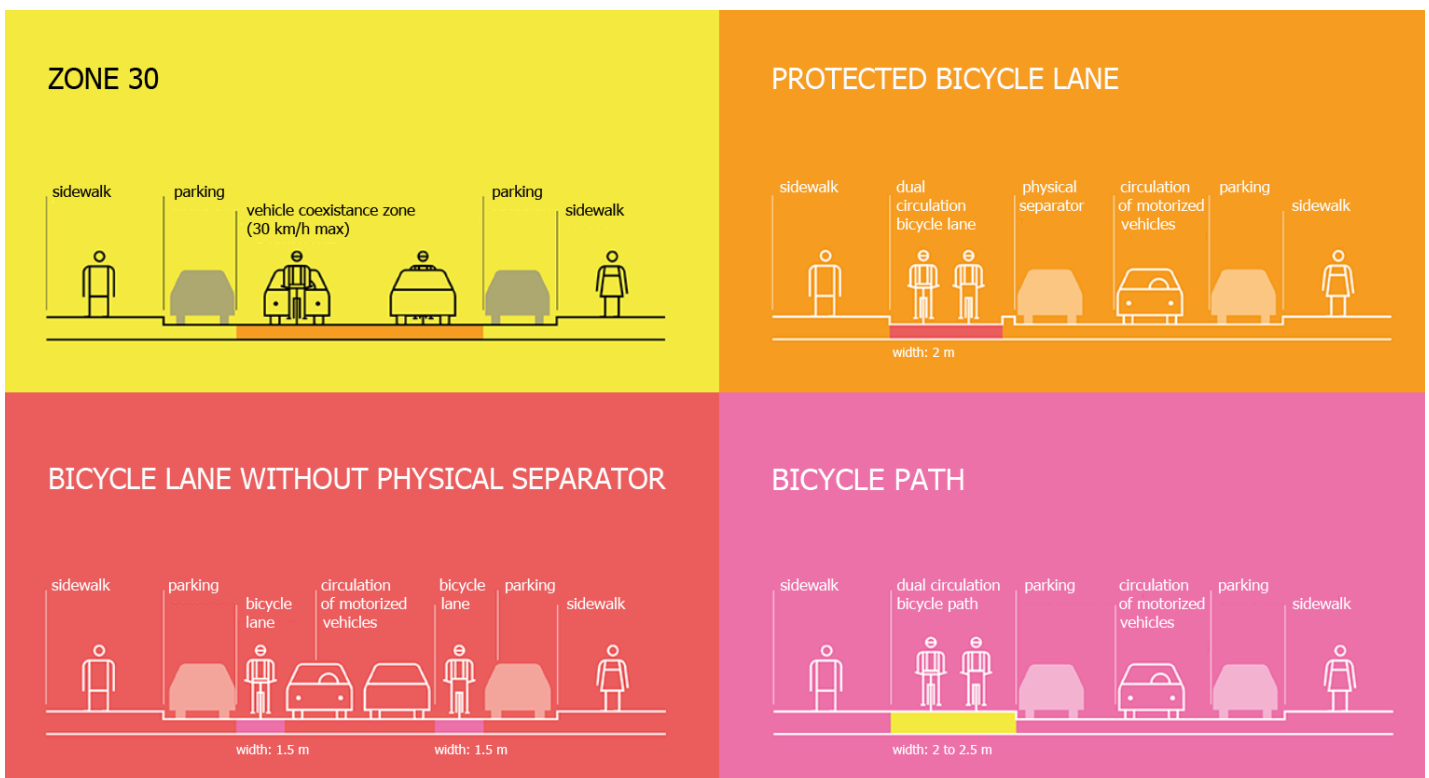

Figure 19 - Types of road infrastructure for bicycle circulation in Uruguay. (Source: Montevideo en Bici website, IM).

According to technicians from the IM's Mobility Planning Unit, there is currently 65 km of infrastructure for bicycle circulation. The IM intends to expand the network of bicycle lanes so that all main roads will have exclusive bicycle infrastructure. Figure 20 illustrates the current map of bicycle infrastructure in Montevideo.

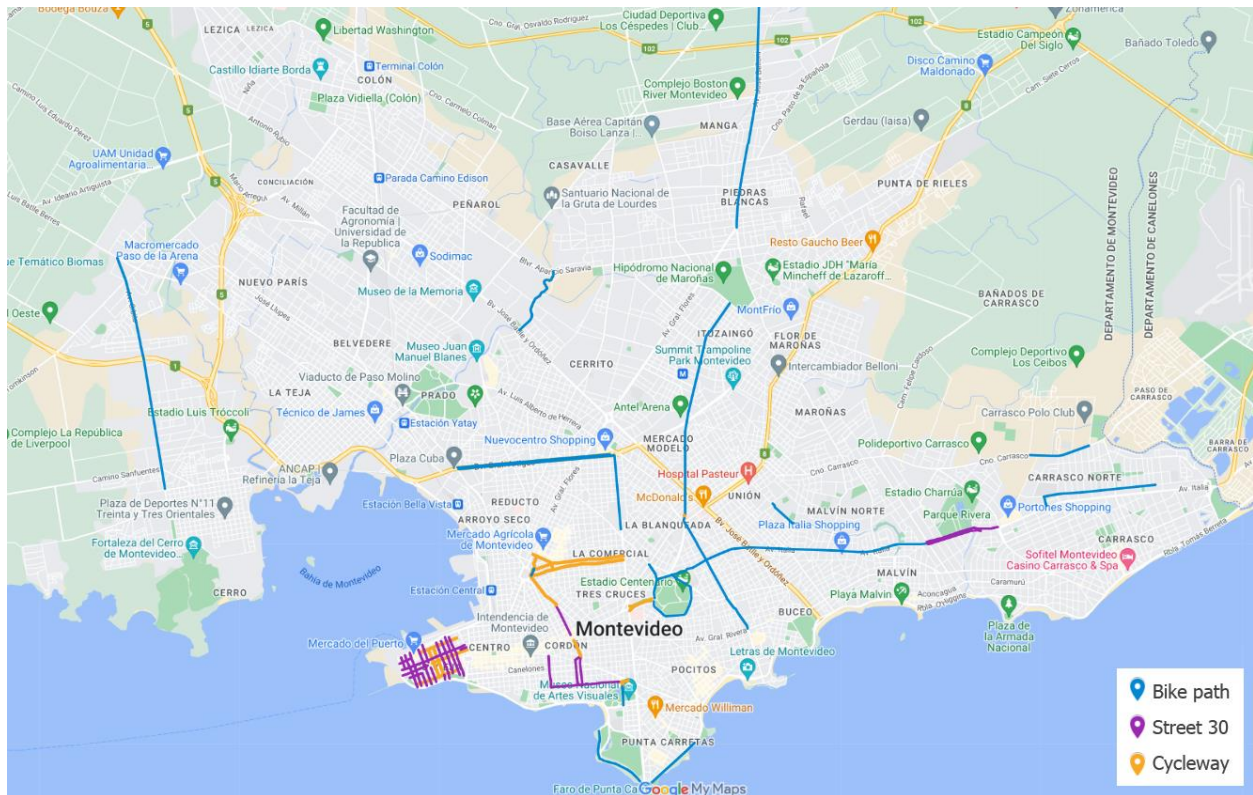

Figure 20 - Existing road infrastructure network for bicycle circulation in Montevideo. (Source: Montevideo en Bici website, IM).

Currently, the reputation of delivery applications is highly dependent on the rating and comments that users make on the app. A key factor is the delivery time of orders, so companies compete to deliver packages as quickly as possible. The use of LEVs for this task could increase delivery times because they generally are slower than the internal combustion motorcycles currently in use. In this regard, having a dense network of cycleways on which LEVs can circulate is very important for their intensive use in last-mile delivery. If LEVs have a lane of their own to ride on, they could avoid traffic obstructions and thus compensate for possible delays caused by driving at lower speeds than traditional motorcycles.

An important point when planning bicycle lanes is to take into account the width of cargo bikes, which are proposed in this roadmap as a solution for last-mile logistics. Since these vehicles generally are wider than traditional bicycles, wider paths will be necessary. This implies changes in urban planning, reductions in the width of the roadway or a reduction in the number of lanes, which is often difficult to implement because decision-makers prioritize private cars over bicycles.

More cycleways and bike paths not only facilitate the use of LEVs but also promote the use of active mobility and reduce the use of individual car transport by providing a means of transport for citizens who wish to travel on a traditional bicycle. It should be emphasized that electrifying transport reduces the problems of GHG emissions into the atmosphere from this sector, but does not solve the mobility problems that may exist in a city, such as traffic jams. It is important to incorporate the concept that an

electric car take up the same space as a combustion car, so in addition to promoting the electrification of transport, it should also try to reduce the use of private cars as a means of transport, since in terms of volume and energy consumed per number of passengers, the individual car is the most inefficient means of transport. A possible solution to this problem is to stimulate the use of LEVs, so it is of utmost importance that DGs have a SUMP designed according to the needs and opportunities of each city, in which the necessary infrastructure for the use of LEVs is planned.

In addition to the necessary road infrastructure for LEVs, another key point for the deployment of these vehicles is to have parking and stopping areas that do not obstruct traffic. Bicycle racks can be enclosed spaces where there are people in charge of control and security or on-street racks for anchoring bicycles. Indoor parking is safer and more reliable than on-street parking, but is more expensive, requiring a higher investment. In Montevideo there is a large number of bicycle parking lots (52 in total) as shown in Figure 21, however, it is necessary to continue installing new ones as the use of these vehicles increases.

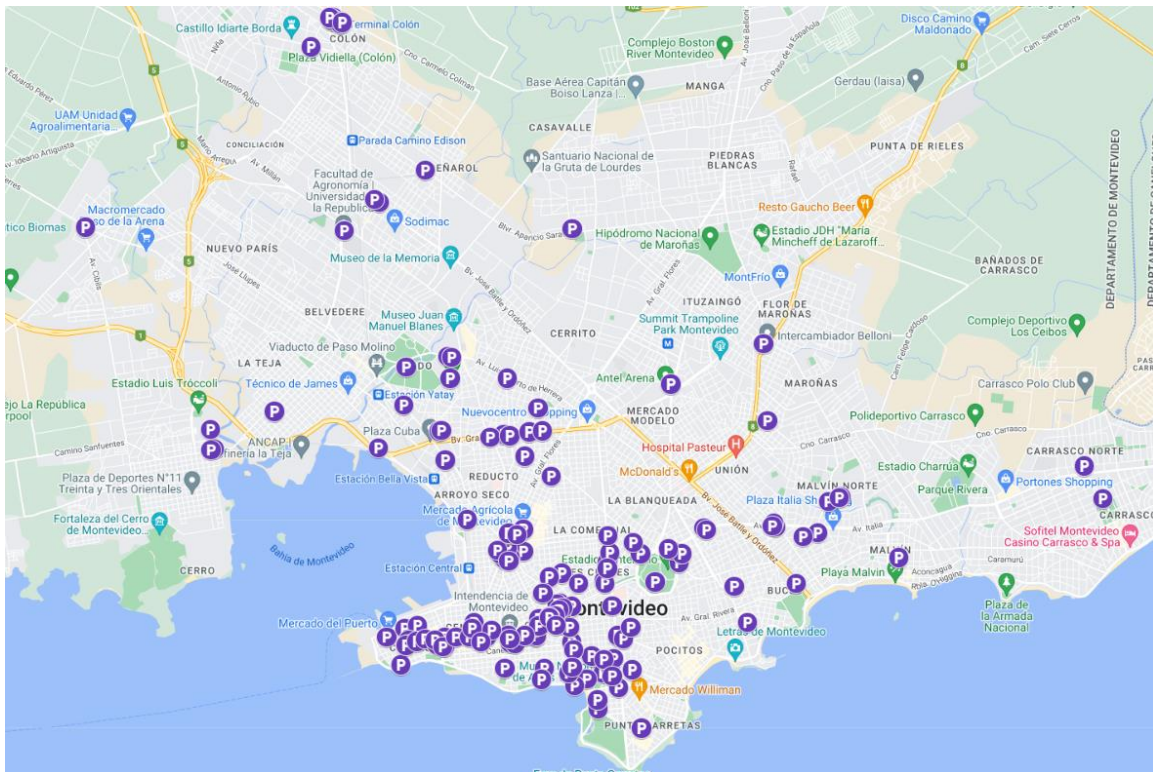

Figure 21 - Existing bicycle parking lots in Montevideo. (Source: Montevideo en Bici website, IM).

6.5. Focus Area 5: EV battery management

One of the main wastes of EVs is their batteries, so the increase of EVs in the vehicle fleet leads to an increase of an environmental liability that must be properly treated. On the one hand, the treatment of



battery waste prevents these materials from being buried and discarded, thus avoiding contamination of the ground and water and air currents with toxic substances. On the other hand, the management of waste batteries privately or governmentally avoids the appearance of informal collectors who can misuse the substances and get hurt. Finally, new batteries can be built from the waste or their materials can be extracted, which reduces the environmental and economic impact of this activity.

There are three ways to manage batteries from EVs that have reached their end of life (EOL) prior to final disposal. These three activities are battery repurposing, refurbishing and finally recycling. These three activities are described in this focus area.

6.5.1. Battery repurposing or “second life”

Typically EV batteries reach their EOL when their capacity is reduced to 60%-80% of the value they had at their BOL. Therefore, such batteries can still be successfully used in less demanding applications such as energy storage systems (ESS).

The reuse of EV batteries in ESS applications brings multiple environmental and economic benefits. By delaying the recycling phase, natural resources are preserved and the need to produce new batteries in ESS is reduced, thus contributing to GHG reduction. The creation of a new market for EV batteries offers new economic opportunities for vehicle and battery manufacturers as well as e-waste companies, which can help reduce the upfront costs of EV batteries. In addition, having more ESS systems helps solve the problem of intermittency of renewable energy (solar, wind) and the asynchrony of peak generation and demand. In addition, this activity creates employment opportunities through the installation and operation of facilities, dismantling and SOH analysis of EV batteries.

Repurposing EV batteries is seen as a promising practice: in an ideal target scenario, the Battery Global Alliance estimates that in 2030, 61% of EV batteries can be repurposed after the end of their automotive use in 2030, substituting to 20 GWh of new ESS which would have been installed. Yet, at present both ESS and the use of EV batteries in these systems are still nascent practices, which explains a lack of information and data. In addition, this practice is not without technological and economic challenges including financial viability, safety, performance and liability concerns.

The battery reuse process generally consists of the following seven steps: 1) removing the battery from the vehicle and assessing its history (if available), 2) sorting batteries according to similarity (chemistry, module dimensions, number of cells, power and capacity, type of BMS, SOH), 3) physically examining modules, 4) testing the battery and module, sometimes the cell, and consequently assessing the residual capacity, 5) possibly removing faulty modules, 6) reassembling as such or in a new battery pack composed of packs having similar power and life, and 7) certify the process according to performance and safety aspects.

EV batteries can be used for a wide variety of purposes, such as supporting the integration of renewable energy into the grid, grid management including peak shaving, backup power or microgrids. Therefore, the use of second-hand EV batteries as ESS can be done in a wide variety of small and large-scale facilities,



such as residential and commercial buildings, telecommunication towers and utilities. Some examples of second-life applications of batteries from e-mobility are described below.

- *Grid support and management.*

Battery energy storage systems (BESS) allow storing energy at periods of low demand at night and to release it during the grid peak, which usually takes place in the early evening (so-called peak “shaving” or leveling mechanism). ESS also enables “energy arbitrage”, i.e. individual decisions to charge and discharge at specific times depending on the different electricity tariffs, with corresponding economic gains. Finally, it can support grid frequency regulation.

- *Storage of renewable energies and integration in the grid.*

Since renewable energies are by nature intermittent sources of power, being able to store energy is critical to support their expansion and ultimately decrease the carbon footprint of the energy sector. The International Energy Agency (IEA) has identified a Sustainable Development Scenario where renewables reach a share of two-thirds of electricity generation output and 37% of final energy consumption by 2040 (IEA, 2019). To balance fluctuations in the grid stemming from an ever-increasing share of renewables in electricity generation, BESS are an alternative option to additional generation sources. Smart BESS also allows leveling peaks in renewable energy generation (“over-generation”), a peak that takes place around noon for solar and generally during the night for wind power generation. Retired EV batteries can help bring down the costs of BESS.

- *Power backup*

EV batteries can be used as back-up power for instance in residential or commercial buildings, and particularly in contexts of instability and limited reliability of the generation or distribution networks, replacing polluting diesel generators.

- *Supporting decentralized energy solutions*

There are places where grid access is difficult or inaccessible, so EV batteries can be used to create microgrids to power the loads in those places.

The battery repurposing is an activity relatively recent, with a number of projects being developed around the world in recent years. The parties involved cover a wide range of private and public industrial sectors, such as large automobile manufacturers, battery manufacturers, e-waste management companies, energy sector players, software designers, etc. Some projects that can be highlighted are the Amsterdam stadium “Johan Crujff Arena” composed of 590 battery packs (340 new and 250 second-life Nissan Leaf batteries with initial capacity of 24 kWh batteries); the second life of Volvo Buses batteries in Gothenburg, Switzerland; and the case of Yinlong Energy (YLE), which manufactures e-buses and sells them to a company that leases them to transportation companies, YLE provides maintenance services during the 10 years and then recovers the EVs, including the batteries, avoiding problems with the collection of batteries.



The main barriers to EV battery reuse are: uncertainty about the SOH and history of the batteries, safety during the process and liability in case of an event, and uncertainty about financial viability since this type of battery would have to be incorporated versus a new one. In addition, collecting batteries and sorting the different types can be a costly and complex step. Volumes also influence the need to ensure sufficient and reliable e-waste collection streams. This can be a major obstacle in countries with limited knowledge and production of automobiles, as well as in the situation of nascent, limited or non-existent e-waste management policies, institutions and facilities.

6.5.2. Battery refurbishing

The refurbishing of batteries takes place once a failure occurs or when a lithium-ion battery has reached their EOL in the vehicle and no second life is possible because of faulty cells or modules. Power and energy requirements can be significantly affected when a battery fails, with undesirable consequences on driving range, final velocity, acceleration and slope compensation. Nevertheless, failed batteries can still be useful if the damage is not total and if an adequate refurbishing is carried out.

Due to the fact that each Original Equipment Manufacturer (OEM) has its specific battery chemistry, cell type, module structure, and package solution, it will be difficult to replace faulty cells from one OEM using those from others. Additionally, safety concerns during the refurbishing stages require professional approaches, trained technicians, specialized teams and specific equipment.

Before starting the refurbishing process, it is necessary to perform a diagnosis and classification, in order to determine if the battery pack can be repurposed, remanufactured or recycled. This result of the assessment depends on the degree of aging, degradation or damage. Extensive information originated during the battery automotive life is crucial in order to make an early diagnosis and an easier classification. After the diagnosis, the classification depends on several factors such as the battery SOH, the remaining useful life, the safety conditions and specific costs of repair. A complexity analysis that includes all those factors is made in order to define the way to follow.

Once the battery has been diagnosed and classified, the refurbishing process can begin. This process consists of the following steps: 1) Screening, 2) Disassembly, 3) Repair (cell replacement & refit), 4) Reassembly and 5) Testing, before a new installation for another application. The whole process is shown in Figure 22.

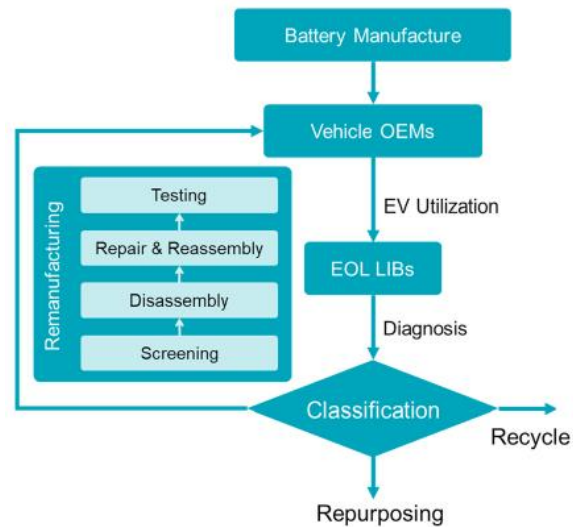

Figure 22 - Life cycle of an EV battery from its manufacture to the possible management of the battery after reaching its EOL. (Source: *Refurbishing Electric Vehicle Batteries, SOLUTIONSplus*).

The steps in the refurbishing process are described below:

- *Screening.*

The objective is to identify the damaged or degraded cells inside an EV battery pack. The process can be performed by using the on-board computer’s information. The BMS of the EV could provide critical information in order to determine the SOH of each cell. Testing the battery pack is another option to make the same determination, discarding useless cells.

- *Disassembly.*

The battery system is dismantled at module or cell level and this step includes opening the battery framework, removing the electrical and mechanical connections between the components, as well as removing auxiliary electronic parts. Generally the process is done manually and requires skilled technicians and specialized equipment, due to the danger of working with high voltage.

- *Cell replacement & refit.*

The repair stage in the refurbishing process is one of the critical phases in order to obtain a good refurbished product. One of the first steps is to replace cells that have been identified as defective, both by analyzing the historical data or by testing modules and/or cells once the pack has been opened. Another important step in the repair step is the verification and refit of the entire electrical circuit, including power cables, control wiring and connectors. Likewise, the BMS at the battery pack level or at the module level must be tested and verified in such a way that its correct operation is ensured to avoid future failures. At this stage, it is important to ensure that all installed cells have identical operating characteristics to ensure that their operation is within a safe range, avoiding undervoltages



and overvoltages. Programming or reprogramming of the BMS must be done in order to ensure a safe operation.

- *Reassembly.*

The reassembly process is very similar to the disassembly step if the remanufactured packs are used for the same purpose. If not, a new design must be carried out to be able to build a new battery pack. The same concept applies to the original BMS, thermal management system, and equalization management system.

- *Testing.*

Final tests must be carried out in order to verify that the performance of the battery pack is satisfactory. For this, certain standards must be met in such a way that the test step is adequately validated by the repair agent. Certain external validation (of the process or of the product) and certifications may eventually be required.

The refurbishing of EV batteries has environmental and economic benefits. From an environmental point of view, this activity postpones the time when the battery needs to be recycled, thus making a longer and more efficient use of the materials present in lithium-ion batteries, which have a substantial environmental impact. It also reduces the need for new batteries, saving on raw materials and their negative impact on the environment. On the other hand, from an economic point of view, EV battery refurbishing can enable discounts on the cost of EV batteries. By extending service life and creating new revenue streams, refurbishing can reduce life-cycle costs and even revalue used batteries. In addition, this activity creates employment opportunities through the installation and operation of facilities, dismantling and SOH analysis of batteries. Despite these arguments, it is estimated that refurbishing will be limited in the long term to only 5% of EV batteries, as the trend of batteries is towards homogeneous aging.

In terms of policies related to the repair and remanufacturing of EV batteries, it is worth mentioning the involvement of different actors and potential stakeholders: 1) government organizations (including regulatory bodies), 2) international organizations, 3) national companies or international participants in the activity and 4) users or consumers. All these actors will have a greater or lesser degree of influence in the elaboration of policies. International organizations can provide support, advice and knowledge regarding the organization and structure of the policies to be applied. The government organizations have the function of carrying out the corresponding regulations and allocating resources to ensure compliance. As for the companies involved, they must define an integrated management system internally, which must comply with existing regulations. Finally, users or consumers play a fundamental role in the selection, use, evaluation and disposal of batteries, which should be subject to the regulations imposed.

6.5.3. Battery recycling

Batteries that have been damaged (in accidents for example) or that have reached their EOL due to severe degradation or aging and cannot be reused, can be recycled to extract part of their components. There



are many different sorts of batteries and different ways of recycling them, being their main components cobalt, lithium and copper. There are mainly two ways to recycle the batteries in order to obtain the different components: one of them is pyrolysis and the other one is hydrometallurgy. Both methods require huge investments as well as an important amount of batteries to make the business profitable.

For countries that do not generate a big amount of batteries, the installation of a pyrolysis or hydrometallurgy plant is not viable, but there is another way of recycling suitable for these markets, which is mechanical recycling. In a mechanical recycling plant the battery is discharged, crushed and the elements (plastic, non-ferrous metals, black mass) are obtained by mechanical separation. Then, each material could be sent to other companies around the world to continue the recycling process.

Regarding policy and legislation for waste lithium batteries, examples could be derived from the EU legislation incorporated into the Battery Directive, which aims to contribute to the protection, preservation and improvement of the quality of the environment by minimizing the negative impact of waste batteries and accumulators. With some exceptions, the normative applies to all batteries and accumulators, regardless of their chemical nature, size or design. To achieve these objectives, the Directive prohibits the commercialization of batteries containing some dangerous substances, defines measures to establish schemes that aim at a high level of collection and recycling, and sets objectives for collection and recycling activities. The Directive establishes provisions on the labeling of batteries and it also aims to improve the environmental performance of all operators involved in the life cycle of batteries such as producers, distributors and users and, in particular, those operators directly involved in the treatment and recycling of battery waste. Manufacturers of batteries or battery-containing products are responsible for the management of waste batteries that they place on the market.

In Uruguay, there is currently no legislation for lithium-ion batteries, there are only regulations for lead-acid batteries (Decree 373/003). This decree is being updated by the MA to include lithium-ion batteries and to stipulate the extended responsibility of the manufacturer or importer in the management of the batteries it markets.

Uruguay has companies with experience in the field of recycling materials and products that are interested in the EV battery recycling industry. An example of this is WERBA S.A. which is a leading company in Uruguay in the recycling of non-ferrous metals. This company is currently focused on a project for the installation of a lithium battery recycling plant, both for electronic devices and e- mobility, since the increase in such waste is rising and there is not a real solution for that waste at country level.

The project anticipates a future problem and it will bring independence in waste management avoiding foreign solutions with all the related problems that it implies (i.e. special permissions such as those from Basel Convention for the transboundary movements, refusal of shipping companies, associated risks, etc.). Likewise, the project aims to recycle the largest possible percentage of the batteries (pointing at the circular economy) creating value from waste. It also has a positive impact on climate change policy promoted by the government and international organizations.



The estimated capacity for the projected plant would be approximately 1000 tons/year and would be based on a mechanical recycling process that would consist of crushing, separating and filtering components. The materials that could be extracted are Iron and Nickel (magnetic metals), copper, aluminum, plastic, black powder (Lithium, Cobalt, Manganese and other Transition Metals). Some of these materials, such as iron, would be recycled in Uruguay, while the rest of the elements would be sent abroad. Materials that cannot be recycled would be a minimal fraction and could be deposited in the sanitary landfill.

7. Conclusions



This roadmap contributes to achieving the objectives that the government has set for e-mobility in Uruguay. Throughout the document, considerations to be taken into account for the scaling up of EVs in the coming years were mentioned. In particular, in accordance with the objective of the roadmap, some activities were listed that should be carried out to replicate the demonstration projects done within the framework of the SOLUTIONSplus project.

In the case of the Ciudadela Terminal component, it was identified that in order to replicate the work done in other terminals in Montevideo or other departments, it is necessary to dialogue with the private sector to convince them to incorporate e-buses. Once more e-buses are incorporated into the fleets of the PTOs, the terminals with the highest flow of these vehicles should be identified as candidates to become multimodal charging hubs, such as the Ciudadela Terminal. An important point for the incorporation of e-buses is the participation of the State by providing economic subsidies for the replacement of the fleet.

On the other hand, in order to create an ecosystem in which the local manufacture of LEVs is profitable, it was identified as a very important aspect to dialogue with last mile delivery companies, presenting successful cases of the use of these LEVs in this area, in order to convince them to incorporate locally manufactured vehicles in their fleets. It was also noted the importance of having a dense network of bicycle lanes to encourage the use of LEVs, both commercially and privately.

The roadmap is intended to be a basic input to help Departmental Governments in the transition to e-mobility, so five focus areas were developed in which some of the most important topics on e-mobility were widely presented. These topics are education and training, charging ecosystem, regulatory measures, urban planning and EV battery management.

In Uruguay, training and education in e-mobility is just beginning to be developed, with very few courses based on a dual teaching modality (theoretical knowledge + practical applications). However, in terms of training, it can be concluded that it is necessary to expand the existing offer, developing an educational system that covers all sectors and levels. This in order to have qualified technicians to solve all kinds of problems related to e-mobility, from technicians who repair EVs to decision makers who make policies for the adoption of EVs.

Regarding the charging ecosystem, Uruguay has ambitious projects in the development of the charging network throughout the country. In particular, the need for a fast charging network was identified as a key point for the deployment of e-mobility, which is already being implemented by UTE, installing the first fast chargers in early 2023. In addition, SMEs are also emerging that aim to provide charging solutions that promote the adoption of EVs.

Uruguay has an incipient regulatory framework for e-mobility that, according to the government's objectives, will be strengthened in the coming years. Among the most important regulatory advances are guidelines on the types of charger connectors, economic benefits for the adoption of EVs and subsidies for the purchase of e-buses. However, it was noted that progress must be made in the regulation of EV batteries, creation of non-economic incentives, regulation of the charging ecosystem and homologation



of retrofitted vehicles. Technicians from MIEM, MA and IM confirmed that work is being done on regulations on these issues.

In terms of urban planning, in order to promote the development of the use of LEVs, the importance of having exclusive circulation lanes for this type of vehicles was noted, in order to guarantee their safe and efficient circulation. In this sense, the IM confirmed that the intention is to expand the network of bicycle lanes in Montevideo. A key point identified is to have a SUMP in Montevideo and other urban areas of the country, which takes into account e-mobility and promotes active mobility, planning the necessary urban infrastructure.

The development of a sustainable, inclusive, and efficient urban transportation system in Montevideo requires the implementation of a range of policies, programs, and projects that prioritize active mobility, promote clean transportation options, and reduce noise pollution. The proposed vision for the city is to create a healthy, vibrant, and livable urban environment that supports the well-being and prosperity of all, and it is believed that the objectives outlined in this policy paper are essential steps towards achieving that vision.

In the short term, it is recommended to prioritize the development of a comprehensive network of bike lanes and pedestrian paths, as well as the provision of safe and secure bike parking facilities at key destinations. It is also suggested to invest in modern, low-emission buses and trams, improving the frequency, reliability, and accessibility of services, and integrating different modes of transport. These measures will promote walking, cycling, and public transportation as safe, convenient, and attractive options for all residents, and help reduce the number of personal cars on the road.

In the medium term, it is recommended to promote the uptake of low-emission modes of transport, including electric vehicles, by investing in charging infrastructure, offering incentives for purchasing and using these vehicles, and creating public awareness campaigns that highlight the benefits of clean transportation. It is also suggested to improve urban planning and infrastructure by prioritizing the needs of pedestrians, cyclists, and public transport users in all new development projects, and promoting mixed-use development that supports compact and walkable neighborhoods.

In the long term, it is recommended developing a city-wide transportation plan that integrates all modes of transport and addresses the challenges of urban logistics and last-mile delivery. It is also suggested the promotion of sustainable freight transport options, such as electric delivery vans and cargo bikes, and encouraging the consolidation and optimization of urban freight movements. To overcome the typical barriers faced by a city like Montevideo, such as limited financial resources, political and social resistance, and the need for stakeholder engagement, engaging in meaningful consultation and collaboration with residents, businesses, and other stakeholders, and developing a communication strategy that highlights the benefits of a sustainable transportation system for all.

In closing, the city authorities, residents, businesses, and other stakeholders are called to work together towards the implementation of the policies, programs, and projects outlined in this policy paper. By doing



so, it would be possible to create a city that is healthy, sustainable, and equitable, and that serves as a model for other cities in the region and beyond.

In addition to the measures outlined above, another key aspect of the vision for a sustainable, inclusive, and efficient urban transportation system in Montevideo is the development of shared electric bus charging infrastructure. This infrastructure would be made available to all public transport operators, whether through an overnight charging scheme or an opportunity charging scheme, to ensure that electric buses can be charged easily and conveniently throughout the city.

To support the development of this infrastructure, it is recommended that the electric tariff be adjusted to encourage the use of electric buses and to ensure that the cost of charging is affordable for public transport operators. This could involve offering discounted rates for electric bus charging, or providing subsidies to offset the cost of installing and maintaining the necessary charging infrastructure.

It is possible to recognize that there may be challenges in implementing this infrastructure, including the need to secure funding, identify suitable locations for charging stations, and coordinate with different stakeholders. However, these challenges can be overcome with careful planning, stakeholder engagement, and a clear commitment to the vision of a sustainable and efficient urban transportation system in Montevideo.

It is believed that the development of shared electric bus charging infrastructure is a crucial component of the proposed vision for a sustainable, inclusive, and efficient urban transportation system in Montevideo. By prioritizing this infrastructure and working to overcome the barriers to its implementation, healthy cities and livable for all residents would be promoted, while also contributing to the global effort to address climate change and reduce greenhouse gas emissions.

Regarding the management of EV batteries, it is concluded that specific regulations on this issue should be developed. In addition, the installation of companies dedicated to the treatment of batteries from e-mobility should be promoted, either through reuse, refurbishing or recycling. It is concluded that this activity has multiple benefits for the country and society, from environmental benefits through the reduction of EV waste, to economic benefits through the creation of new sources of employment.

In conclusion, Uruguay promotes being a pioneer country in the region in the transition to e-mobility, given the potential of renewable sources of electric energy available. In this sense, it is expected that this roadmap will contribute as a basic input to Departmental Governments in this transition.



8. References

- **Guía sobre Movilidad Urbana Eléctrica en Uruguay**, February 2022, Euroclima+.
- **Guía para la Planificación de la Movilidad Urbana Sostenible en Uruguay**, September 2021, Euroclima+.
- **Estrategia Climática de Largo Plazo de Uruguay**, Sistema Nacional de Respuesta al Cambio Climático, 2021.
- **Primera Contribución Determinada a nivel Nacional al Acuerdo de París**, November 2017.
- **Política Nacional de Cambio Climático**, Sistema Nacional de Respuesta al Cambio Climático, 2017.
- **Memorias del 1er Foro Internacional de Electromovilidad & Propuesta de Hoja de Ruta para la Electromovilidad en Ecuador**, September 2018, Ministerio de Transporte y Obras Públicas.
- **Estrategia Nacional de Electromovilidad**, Ministerio de Energía, Ministerio de Transporte y Telecomunicaciones, Ministerio del Medio Ambiente de Chile.
- **Plan de Movilidad**, February 2010, Intendencia de Montevideo.
- **Análisis sobre las Oportunidades, Desafíos y el Marco Regulatorio Necesario para la Conversión (Retrofit) de Vehículos de Combustión a Eléctricos en el Uruguay**, MOVÉS, 2022.
- **Estudio comparativo de nivel de ruido generado por el transporte público convencional y eléctrico**, MOVÉS & CSI Ingenieros, January 2021.
- **Hacia la Movilidad Eficiente y Sostenible en Uruguay - Logros obtenidos, lecciones aprendidas y líneas de trabajo a futuro**, MOVÉS, November 2022.
- **Policy Brief on Public Charging Infrastructure - Promoting successful roll-out strategies and business models**, International Energy Agency (IEA), April 2022.
- **Repurposing Electric Vehicle Batteries - Secondary applications as energy storage systems**, SOLUTIONSplus, October 2020.
- **Refurbishing Electric Vehicle Batteries**, SOLUTIONSplus, October 2020.
- **Recycling Plant for Waste Battery Treatment**, SOLUTIONSplus, October 2020.

